



RF-BM-2652P2 and RF-BM-2652P2I CC2652P
SimpleLink™ Multiprotocol 2.4 GHz Wireless Module
with Integrated Power Amplifier

Version 1.1

Shenzhen RF-star Technology Co., Ltd.

Jan. 23th, 2024

All rights reserved. Those responsible for unauthorized reproduction will be prosecuted.

1 Device Overview

1.1 Description

RF-BM-2652P2(I) is an RF module based on TI lower-power CC2652P SoC, which is a multiprotocol 2.4 GHz wireless module supporting Thread, Zigbee®, Bluetooth® 5.2 Low Energy, IEEE 802.15.4, IPv6-enabled smart objects (6LoWPAN), proprietary systems, including the TI 15.4-Stack (2.4 GHz), and concurrent multiprotocol through a Dynamic Multiprotocol Manager (DMM) driver. It integrates a 48 MHz crystal and a 32.768 kHz crystal, 352 kB of in-system Programmable Flash, 256 kB ROM, 8 kB of Cache SRAM, and 80 kB of ultra-low leakage SRAM. Its ARM® Cortex®-M4F core application processor can operate at an extremely low current at flexible power modes. And the module enables long-range and low-power applications using an integrated +20 dBm high-power amplifier with best-in-class transmit current consumption at 85 mA. It features a small size, robust connection distance, and rigid reliability. Optional antenna output modes (PCB, IPEX connector, and half-hole interface) make the module more convenient for application and development.

1.2 Key Features

- RF Section
 - Bluetooth 5.2 Low Energy
 - ZigBee, Thread
 - IEEE 802.15.4
 - IPv6-enabled smart objects (6LoWPAN)
 - Proprietary systems
 - SimpleLink™ TI 15.4-Stack (2.4 GHz)
 - Dynamic Multiprotocol Manager (DMM) driver
- TX power: up to +20 dBm with temperature compensation
- Excellent receiver sensitivity
 - -105 dBm for Bluetooth 125 kbps (LE coded PHY)
 - -100 dBm for 802.15.4 (2.4 GHz)
- Wide Operation Range
 - 1.8 V to 3.8 V single power supply
 - Operating temperature: -40 °C to +85 °C
 - Storage temperature: -40 °C to +125 °C
- Microcontroller
 - Powerful 48 MHz ARM® Cortex®-M4F processor
 - EEMBC CoreMark® score: 148
 - 2-pin cJTAG and JTAG debugging
 - Support OTA upgrade
- Memory
 - 352 kB of in-system programmable flash
 - 256 kB of ROM for protocols and library functions
 - 8 kB of cache SRAM (Alternatively available as general-purpose RAM)
 - 80 kB of ultra-low leakage SRAM. The SRAM is protected by parity to ensure high reliability of operation.
- Ultra-low power sensor controller with 4 kB of SRAM
 - Sample, store, and process sensor data
 - Operation independent from system CPU
 - Fast wake-up for low-power operation
- Rich Peripherals
 - 23 GPIOs, digital peripheral pins can be routed to any GPIOs
 - 4 × 32-bit or 8 × 16-bit general-purpose timers
 - 12-bit ADC, 200 kSamples/s, 8 channels
 - 2 × comparators with internal reference DAC (1 × continuous time, 1 × ultra-low power)
 - Programmable current source

- 2 × UART
- 2 × SSI (SPI, Microwave, TI)
- I²C
- I²S
- Real-time clock (RTC)
- Capacitive sensing, up to 8 channels
- Integrated temperature and battery monitor
- Security Enablers
 - AES 128-bit and 256-bit Crypto accelerator
 - ECC and RSA public key hardware accelerator
 - SHA2 accelerator (full suite up to SHA-512)
 - True random number generator (TRNG)
- External system
 - On-chip buck DC/DC converter
- Dimension: 30.0 mm × 16.4 mm × 2.25 mm
- RF-BM-2652P2 and RF-BM-2652P2I Certificates:
 - FCC
 - CE

1.3 Applications

- 2400 to 2480 MH ISM and SRD systems with down to 4 kHz of receive bandwidth
- Home and building automation
- Building security system
- HVAC system
- Gateway
- IP network camera
- Fire safety system
- Smart grid
- Automatic meter reading
- Industrial transport
- Wireless sensor networks
- Factory automation and control
- Wireless healthcare applications
- Energy harvesting applications
- Asset tracking and management
- Electronic Shelf Label (ESL)
- Wired networking
- Small business router
- Portable electronics
- Set-top box
- Connected peripherals
- Keyboard and keypads
- Home theater & entertainment
- Electronic and robotic toys
- Wearables

1.4 Functional Block Diagram

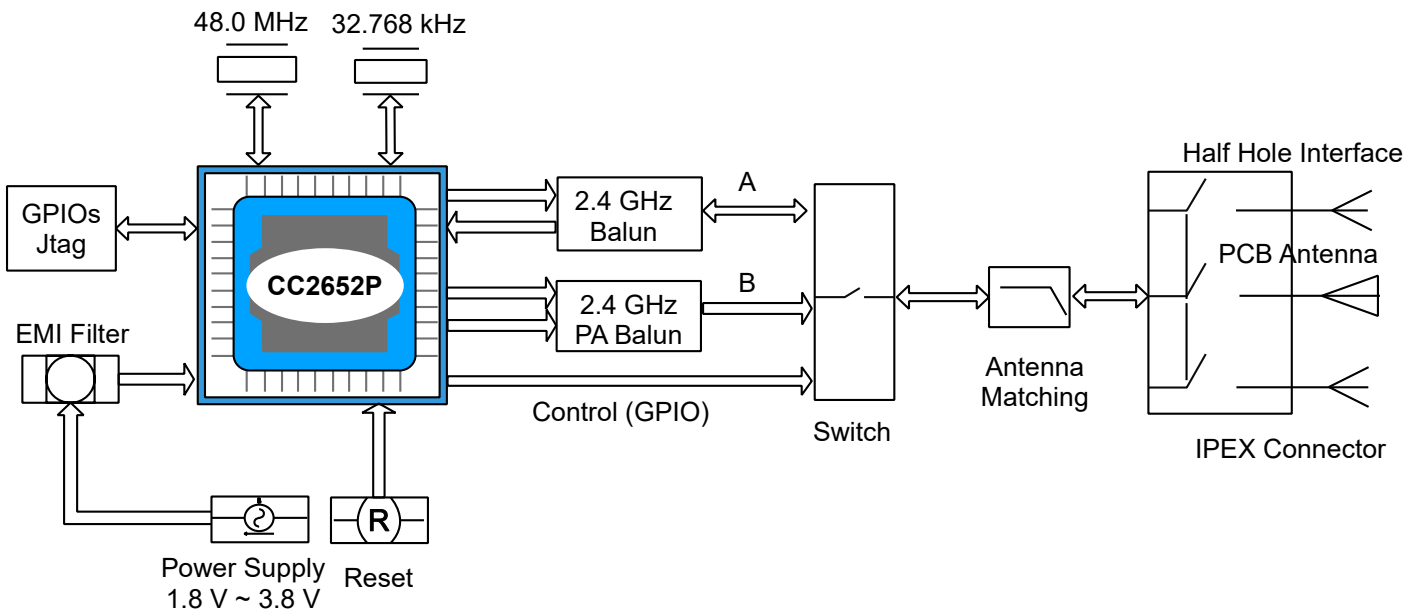

Figure 1. Functional Block Diagram of RF-BM-2652P2(I)

1.5 Part Number Conventions

The part numbers are of the form of RF-BM-2652P2(I) where the fields are defined as follows:

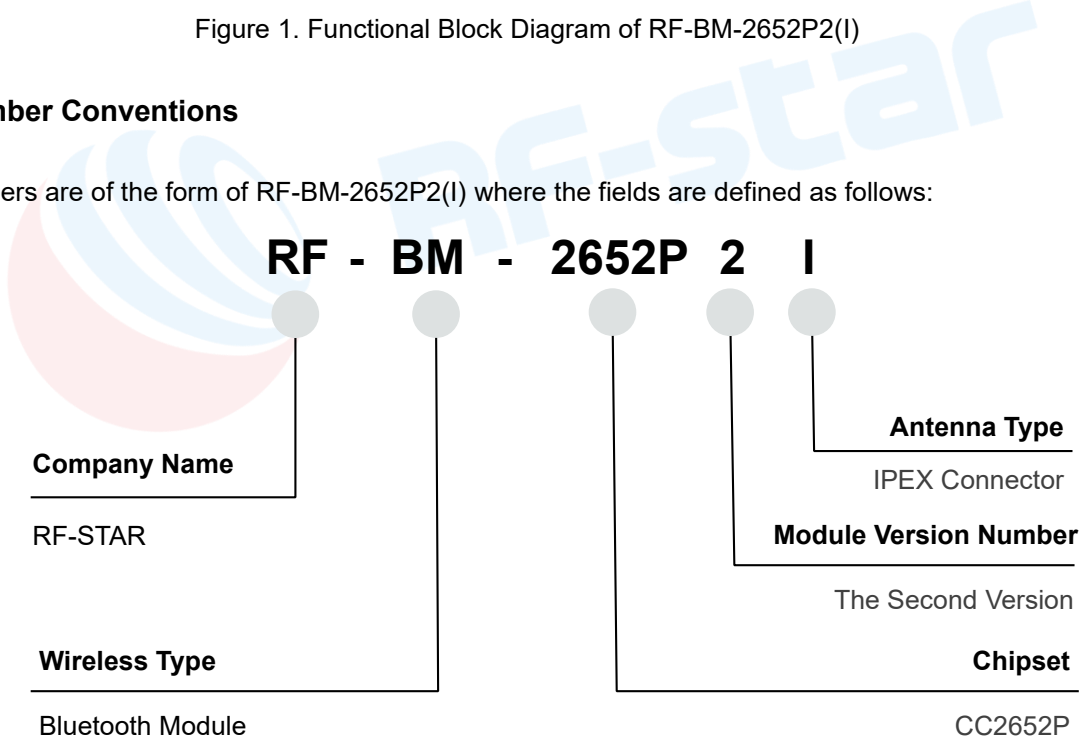

Figure 2. Part Number Conventions of RF-BM-2652P2(I)

Table of Contents

1 Device Overview	2
1.1 Description.....	2
1.2 Key Features	2
1.3 Applications.....	3
1.4 Functional Block Diagram	4
1.5 Part Number Conventions	4
Table of Contents.....	5
2 Module Configuration and Functions	7
2.1 Module Parameters.....	7
2.2 Module Pin Diagram	8
2.3 Pin Functions.....	8
3 Specifications	10
3.1 Recommended Operating Conditions	10
3.2 Handling Ratings.....	10
3.3 PA Output Control	10
4 Application, Implementation, and Layout.....	11
4.1 Module Photos.....	11
4.2 Recommended PCB Footprint.....	11
4.3 Schematic Diagram.....	12
4.4 Reference Design	13
4.5 Antenna.....	13
4.5.1 Antenna Design Recommendation	13
4.5.2 Antenna Output Mode Modification.....	14
4.5.3 External Antenna Design Recommendation of the Half-Hole ANT Pin.....	15
4.5.4 IPEX Connector Specification	16
4.6 Basic Operation of Hardware Design	17
4.7 Trouble Shooting.....	18
4.7.1 Unsatisfactory Transmission Distance.....	18
4.7.2 Vulnerable Module.....	18
4.7.3 High Bit Error Rate	18
4.8 Electrostatics Discharge Warnings	19

4.9 Soldering and Reflow Condition.....	19
5 Optional Package Specification	21
6 Certificate.....	23
6.1 FCC.....	23
6.2 CE.....	23
7 Revision History	24
8 Contact Us.....	25



2 Module Configuration and Functions

2.1 Module Parameters

Table 1. Parameters of RF-BM-2652P2(I)

Chipset	CC2652P
Supply Power Voltage	1.8 V ~ 3.8 V, 3.3 V is recommended
Frequency	2402 MHz ~ 2480 MHz
Maximum Transmit Power	+20.0 dBm
Receiving Sensitivity	-100 dBm @ 802.15.4 (2.4 GHz) -105 dBm @ Bluetooth 125 kbps (LE Coded PHY)
GPIO	23
Flash	352 kB
ROM	256 kB
SRAM	88 kB
Power Consumption	RX current: 6.9 mA TX current: 7.3 mA @ 0 dBm 9.6 mA @ 5 dBm 22 mA @ 10 dBm 85 mA @ 20 dBm MCU 48 MHz (CoreMark): 3.4 mA (71 μ A/MHz) Sensor Controller: 30.1 μ A @ Low Power-Mode, 2 MHz, running infinite loop 808 μ A @ Active-Mode, 24 MHz, running infinite loop Standby: 0.94 μ A Shutdown: 150 nA
Support Protocol	Thread, ZigBee, BLE5.2, IEEE 802.15.4, 6LoWPAN, proprietary systems, SimpleLink™ TI 15.4 stack (2.4 GHz)
Crystal	48 MHz, 32.768 kHz
Package	SMT packaging (1.27-mm half-hole pitch stamp stick)
Dimension	30.0 mm × 16.4 mm × 2.25 mm
Type of Antenna	RF-BM-2652P2: PCB antenna RF-BM-2652P2I: IPEX connector, ANT pin
Operating Temperature	-40 °C ~ +85 °C
Storage Temperature	-40 °C ~ +125 °C

2.2 Module Pin Diagram

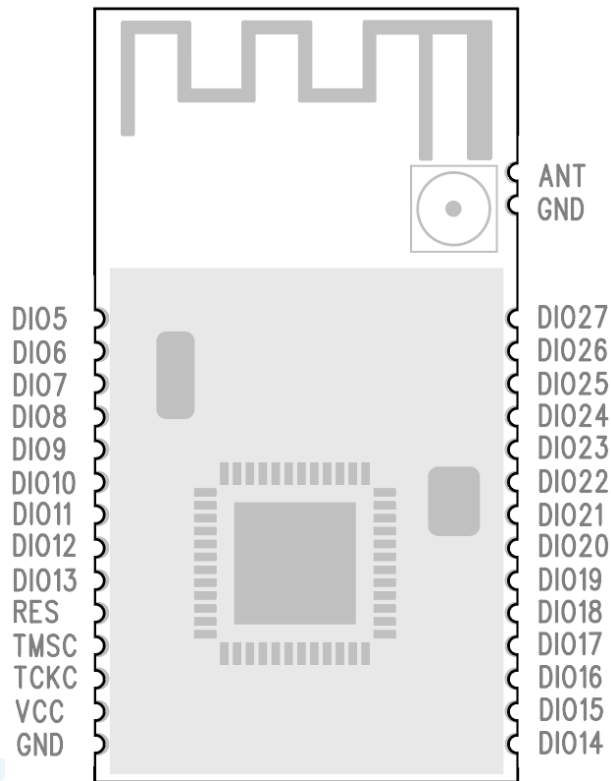

Figure 3. Pin Diagram of RF-BM-2652P2(I)

2.3 Pin Functions

Table 2. Pin Diagram of RF-BM-2652P2(I)

Pin	Name	Chip Pin	Function	Description
1	DIO5	DIO_5	Digital	GPIO, high-drive capability
2	DIO6	DIO_6	Digital	GPIO, high-drive capability
3	DIO7	DIO_7	Digital	GPIO, high-drive capability
4	DIO8	DIO_8	Digital	GPIO
5	DIO9	DIO_9	Digital	GPIO
6	DIO10	DIO_10	Digital	GPIO
7	DIO11	DIO_11	Digital	GPIO
8	DIO12	DIO_12	Digital	GPIO
9	DIO13	DIO_13	Digital	GPIO
10	RES	RESET_N	Digital	Reset, active low. Internal pullup.
11	JTAG_TMISC	JTAG_TMISC	Digital	JTAG TMISC, high-drive capability
12	JTAG_TCKC	JTAG_TCKC	Digital	JTAG TCKC

13	VCC	VCC	-	Power supply: 1.8 V ~ 3.8 V, recommended to 3.3 V
14	GND	GND	Ground	Ground
15	DIO14	DIO_14	Digital	GPIO
16	DIO15	DIO_15	Digital	GPIO
17	DIO16	DIO_16	Digital	GPIO, JTAG_TDO, high-drive capability
18	DIO17	DIO_17	Digital	GPIO, JTAG_TDI, high-drive capability
19	DIO18	DIO_18	Digital	GPIO
20	DIO19	DIO_19	Digital	GPIO
21	DIO20	DIO_20	Digital	GPIO
22	DIO21	DIO_21	Digital	GPIO
23	DIO22	DIO_22	Digital	GPIO
24	DIO23	DIO_23	Digital or Analog	GPIO, analog capability
25	DIO24	DIO_24	Digital or Analog	GPIO, analog capability
26	DIO25	DIO_25	Digital or Analog	GPIO, analog capability
27	DIO26	DIO_26	Digital or Analog	GPIO, analog capability
28	DIO27	DIO_27	Digital or Analog	GPIO, analog capability
29	GND	GND	Ground	Ground
30	ANT		-	External antenna interface

3 Specifications

3.1 Recommended Operating Conditions

Functional operation does not guarantee performance beyond the limits of the conditional parameter values in the table below. Long-term work beyond this limit will affect the reliability of the module more or less.

Table 3. Recommended Operating Conditions of RF-BM-2652P2(I)

Items	Condition	Min.	Typ.	Max.	Unit
Operating Supply Voltage	/	1.8	3.3	3.8	V
Operating Temperature	/	-40	+25	+85	°C

3.2 Handling Ratings

Table 4. Handling Ratings of RF-BM-2652P2(I)

Items	Condition	Min.	Typ.	Max.	Unit
Storage Temperature	Tstg	-40	+25	+125	°C
Human Body Model	HBM		±2000		V
Moisture Sensitivity Level			3		
Charged Device Model			±500		V

3.3 PA Output Control

The module's high transmit power (>5 dBm) is achieved by controlling the outputs of DIO28 and DIO29 to switch the radio frequency switch and then enable the PA (HIGH POWER).

As shown in Table 3, when DIO28 outputs a low level and DIO29 outputs a high level, HIGH PA is turned on, and the module RF can output a transmit power greater than +5 dBm, with a maximum of +20 dBm.

When DIO28 outputs a high level and DIO29 outputs a low level, HIGH PA is turned off and the maximum transmit power of the module can only be +5 dBm.

Table 3. RF Control Truth Table

Power	DIO28 (Output)	DIO29 (Output)
+5 dBm ~ + 20 dBm (PA)	0	1
< 5 dBm	1	0

4 Application, Implementation, and Layout

4.1 Module Photos

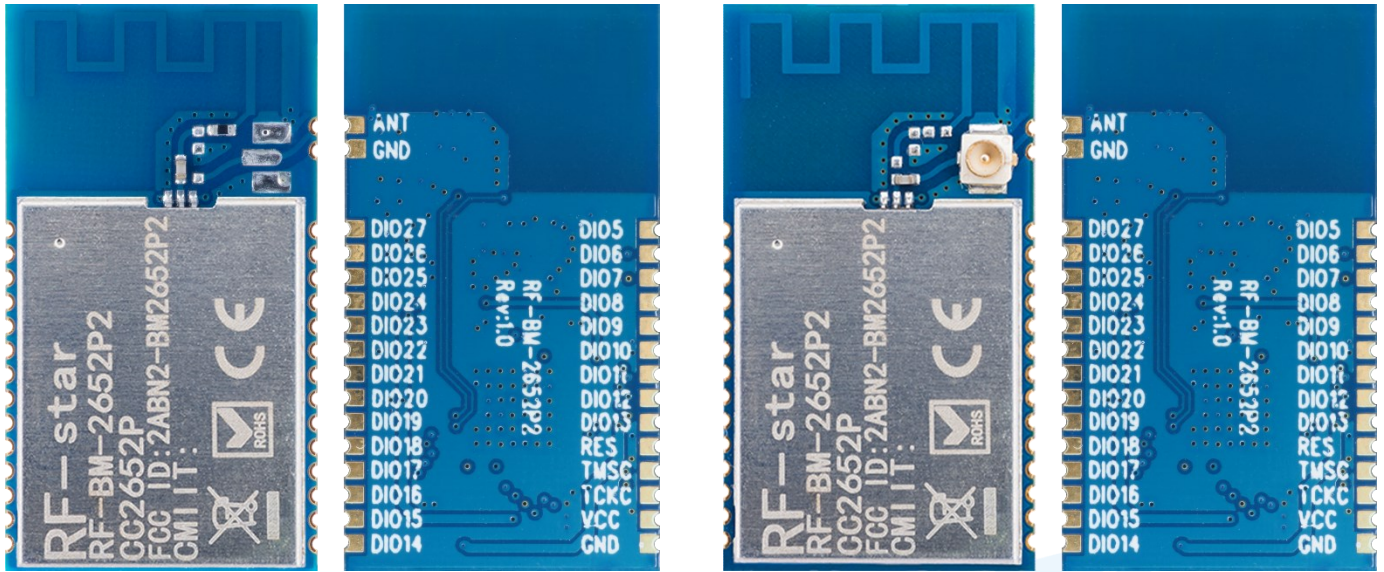

RF-BM-2652P2

RF-BM-2652P2I

Figure 3. Photos of RF-BM-2652P2(I)

4.2 Recommended PCB Footprint

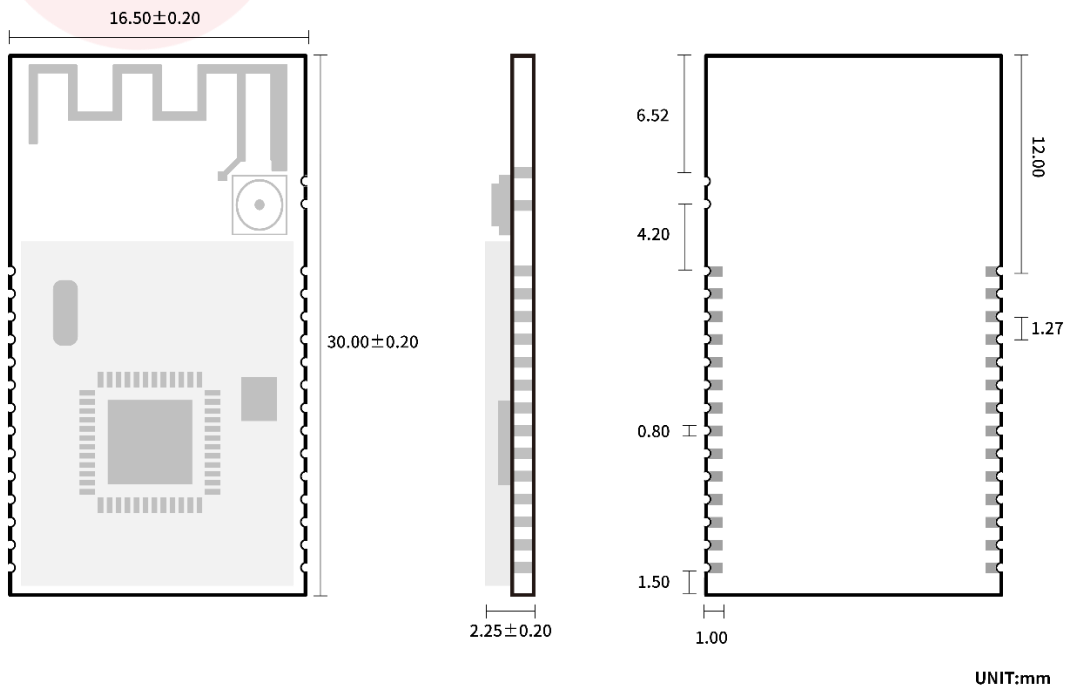

Figure 4. Recommended PCB Footprint of RF-BM-2652P2(I)

4.3 Schematic Diagram

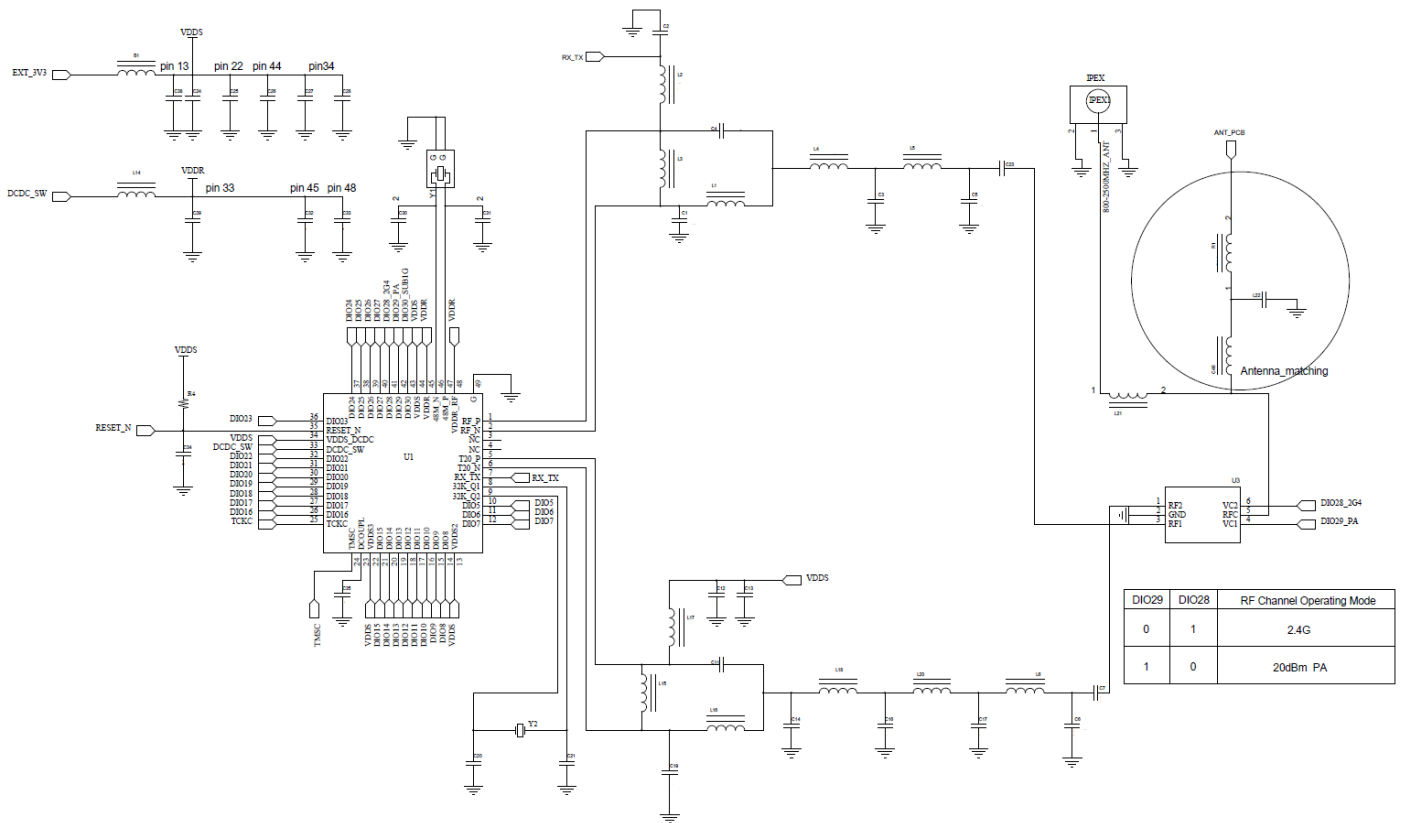

Figure 5. Schematic Diagram of RF-BM-2652P2(I)

4.4 Reference Design

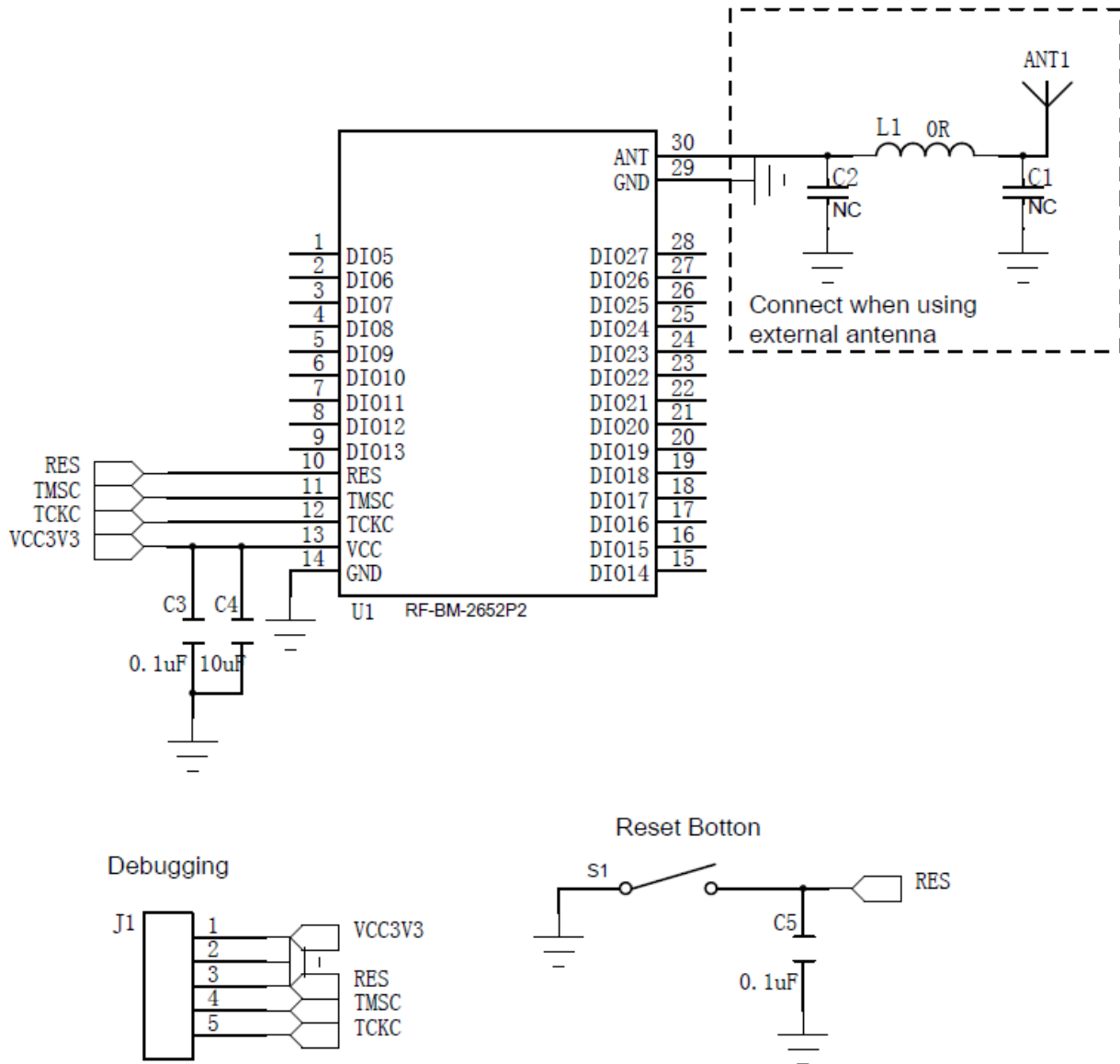

Figure 5. Reference Design of RF-BM-2652P2(I)

4.5 Antenna

4.5.1 Antenna Design Recommendation

1. The antenna installation structure has a great influence on the module performance. It is necessary to ensure that the antenna is exposed and preferably vertically upward. When the module is installed inside of the case, a high-quality antenna extension wire can be used to extend the antenna to the outside of the case.
2. The antenna must not be installed inside the metal case, which will cause the transmission distance to be greatly

weakened.

3. The recommendation of antenna layout.

The inverted-F antenna position on PCB is free-space electromagnetic radiation. The location and layout of the antenna are key factors to increase the data rate and transmission range.

Therefore, the layout of the module antenna location and routing is recommended as follows:

- (1) Place the antenna on the edge (corner) of the PCB.
- (2) Make sure that there is no signal line or copper foil in each layer below the antenna.
- (3) It is best to hollow out the antenna position in the following figure to ensure that the S11 of the module is minimally affected.

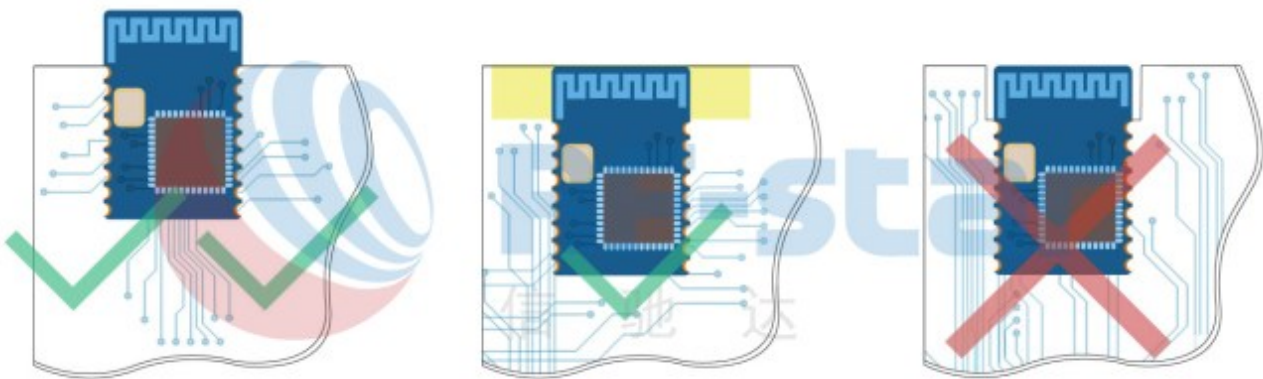

Figure 4. Recommendation of Antenna Layout

Note: The hollow-out position is based on the antenna used.

4.5.2 Antenna Output Mode Modification

This module has three antenna output modes, namely PCB, IPEX connector and stamp RF ANT interface output (RF ANT pin, see the pin definition table for details).

As shown in the figure below, the components in the red box use PCB antenna (RF-BM-2652P2). If you want to switch to IPEX connector (RF-BM-2652P2I) or ANT pin external antenna test effect, you can change the component in the red box by rotating it 90 degrees and solder it to the green box position.

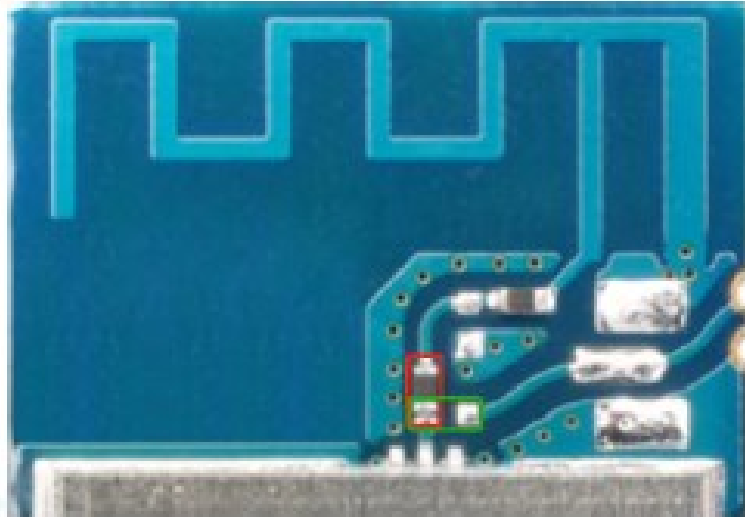

Figure 5. Antenna Output Mode Modification of RF-BM-2652P2(I)

4.5.3 External Antenna Design Recommendation of the Half-Hole ANT Pin

1. A Π -type matching circuit is reserved for the antenna, and $50\ \Omega$ impedance control is performed on the RF traces. The traces are as short as possible, and 135° or arc traces are used as much as possible. No vias are used to change layers. More GND vias are placed around the RF traces.

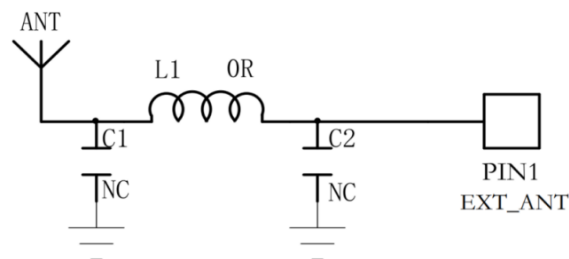

Figure 6. Reference Design of the External Antenna

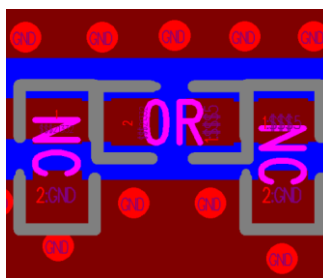

Figure 7. Reference Design of the External Antenna Traces

2. The RF trace width and copper-clad spacing can be calculated by SI9000 software, and the impedance is controlled to $50\ \Omega$ according to the actual board thickness, number of layers, plate, dielectric thickness, dielectric constant, copper thickness, line width, line spacing, and solder mask thickness.

Example: FR4 is a double-layer board with a thickness of 1.0 mm. Through calculation, the width of the trace is 0.8254 mm, and the spacing between traces and copper is 0.22 mm.

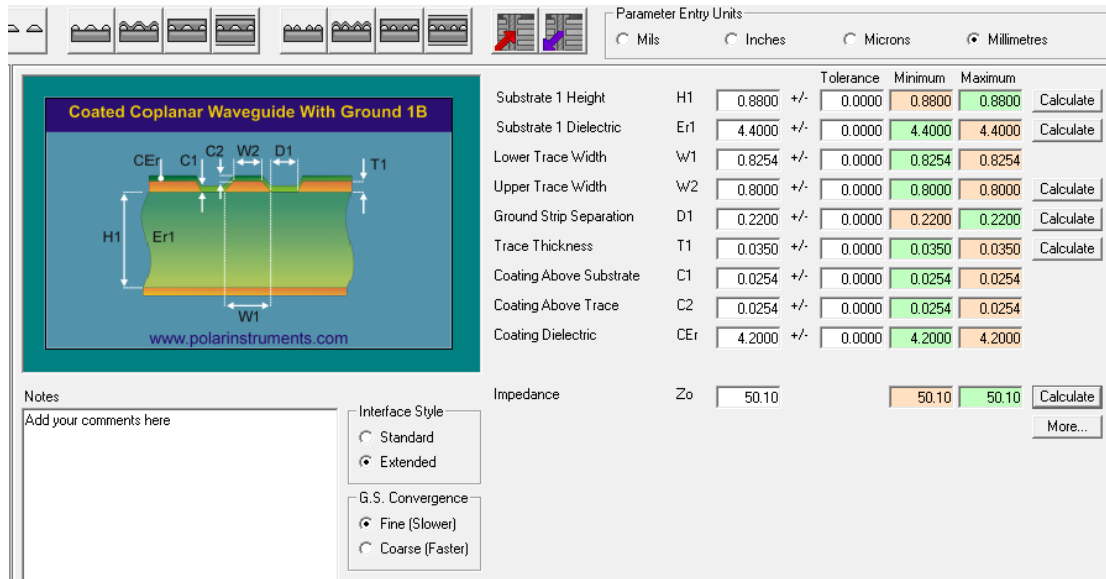

Figure 8. SI9000 Impedance Calculation Diagram

4.5.4 IPEX Connector Specification

RF-BM-2652P2I module is integrated the IPEX version 1 antenna seat, the specification of the antenna seat is as follows:

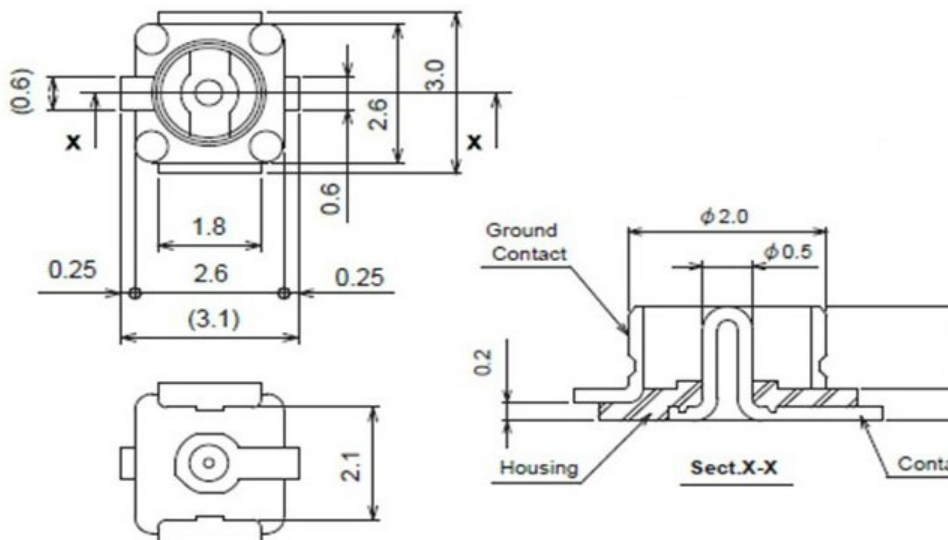

Figure 9. Specification of Antenna Seat

The specification of the IPEX wire end is as follows:

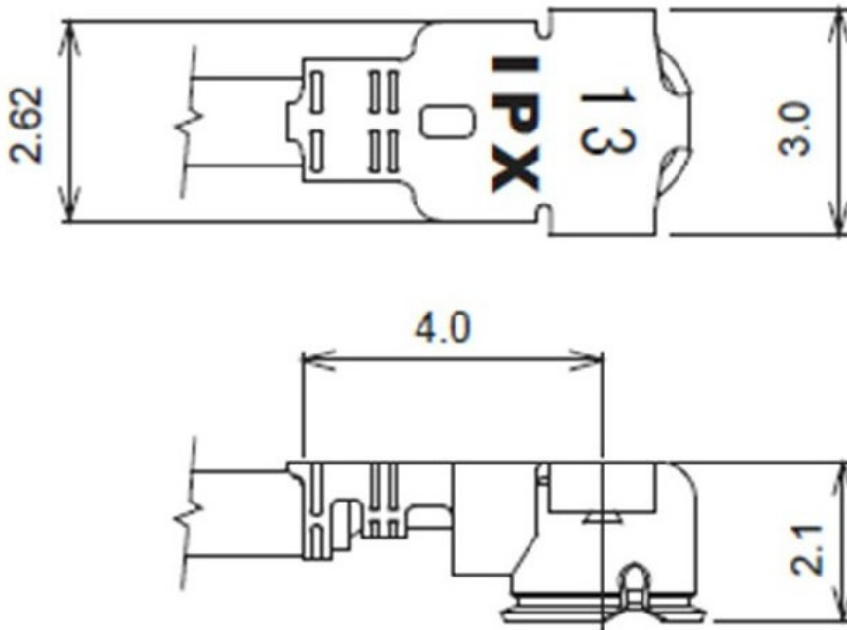

Figure 10. Specification of IPEX Wire

4.6 Basic Operation of Hardware Design

1. It is recommended to offer the module a DC stabilized power supply, a tiny power supply ripple coefficient, and reliable ground. Please pay attention to the correct connection between the positive and negative poles of the power supply. Otherwise, the reverse connection may cause permanent damage to the module.
2. Please ensure the supply voltage is between the recommended values. The module will be permanently damaged if the voltage exceeds the maximum value. Please ensure a stable power supply and no frequently fluctuating voltage.
3. When designing the power supply circuit for the module, it is recommended to reserve more than 30% of the margin, which is beneficial to the long-term stable operation of the whole machine. The module should be far away from the power electromagnetic, transformer, high-frequency wiring, and other parts with large electromagnetic interference.
4. The bottom of the module should avoid high-frequency digital routing, high-frequency analog routing, and power routing. If it has to route the wire on the bottom of the module, for example, it is assumed that the module is soldered to the Top Layer, the copper must be spread on the connection part of the top layer and the module, and be close to the digital part of the module and routed in the Bottom Layer (all copper is well-grounded).
5. Assuming that the module is soldered or placed in the Top Layer, it is also wrong to randomly route the Bottom Layer or other layers, which will affect the spurs and receiving sensitivity of the module to some degree.
6. Assuming that there are devices with large electromagnetic interference around the module, which will greatly affect the module performance. It is recommended to stay away from the module according to the strength of the

interference. If circumstances permit, appropriate isolation and shielding can be done.

7. Assuming that there are routings of large electromagnetic interference around the module (high-frequency digital, high-frequency analog, power routings), which will also greatly affect the module performance. It is recommended to stay away from the module according to the strength of the interference. If circumstances permit, appropriate isolation and shielding can be done.
8. It is recommended to stay away from the devices whose TTL protocol is the same 2.4 GHz physical layer, for example, USB 3.0.

4.7 Trouble Shooting

4.7.1 Unsatisfactory Transmission Distance

1. When there is a linear communication obstacle, the communication distance will be correspondingly weakened. Temperature, humidity, and co-channel interference will lead to an increase in the communication packet loss rate. The performances of ground absorption and reflection of radio waves will be poor when the module is tested close to the ground.
2. Seawater has a strong ability to absorb radio waves, so the test results by the seaside are poor.
3. The signal attenuation will be very obvious if there is metal near the antenna or if the module is placed inside the metal shell.
4. The incorrect power register set or the high data rate in the open air may shorten the communication distance. The higher the data rate, the closer the distance.
5. The low voltage of the power supply is lower than the recommended value at ambient temperature, and the lower the voltage, the smaller the power is.
6. The unmatchable antennas and modules or the poor quality of antenna will affect the communication distance.

4.7.2 Vulnerable Module

1. Please ensure the supply voltage is between the recommended values. The module will be permanently damaged if the voltage exceeds the maximum value. Please ensure a stable power supply and no frequently fluctuating voltage.
2. Please ensure the anti-static installation and the electrostatic sensitivity of high-frequency devices.
3. Due to some humidity-sensitive components, please ensure the suitable humidity during installation and application. If there is no special demand, it is not recommended to use at too high or too low temperature.

4.7.3 High Bit Error Rate

1. There are co-channel signal interferences nearby. It is recommended to be away from the interference sources or modify the frequency and channel to avoid interferences.

2. The unsatisfactory power supply may also cause garbled. It is necessary to ensure the power supply's reliability.
3. If the extension wire or feeder wire is of poor quality or too long, the bit error rate will be high.

4.8 Electrostatics Discharge Warnings

The module will be damaged by the discharge of static. RF-star suggests that all modules should follow the 3 precautions below:

1. According to the anti-static measures, bare hands are not allowed to touch modules.
2. Modules must be placed in anti-static areas.
3. Take the anti-static circuitry (when inputting HV or VHF) into consideration in product design.

Static may result in the degradation in performance of the module, even causing failure.

4.9 Soldering and Reflow Condition

1. Heating method: Conventional Convection or IR/convection.
2. Solder paste composition: Sn96.5/Ag3.0/Cu0.5
3. Allowable reflow soldering times: 2 times based on the following reflow soldering profile.
4. Temperature profile: Reflow soldering shall be done according to the following temperature profile.
5. Peak temperature: 245 °C.

Table 5. Temperature Table of Soldering and Reflow

Profile Feature	Sn-Pb Assembly	Pb-Free Assembly
Solder Paste	Sn63 / Pb37	Sn96.5 / Ag3.0 / Cu0.5
Min. Preheating Temperature (T_{min})	100 °C	150 °C
Max. Preheating Temperature (T_{max})	150 °C	200 °C
Preheating Time (T_{min} to T_{max}) (t_1)	60 s ~ 120 s	60 s ~ 120 s
Average Ascend Rate (T_{max} to T_p)	Max. 3 °C/s	Max. 3 °C/s
Liquid Temperature (T_L)	183 °C	217 °C
Time above Liquidus (t_L)	60 s ~ 90 s	30 s ~ 90 s
Peak Temperature (T_p)	220 °C ~ 235 °C	230 °C ~ 250 °C
Average Descend Rate (T_p to T_{max})	Max. 6 °C/s	Max. 6 °C/s
Time from 25 °C to Peak Temperature (t_2)	Max. 6 minutes	Max. 8 minutes
Time of Soldering Zone (t_p)	20±10 s	20±10 s

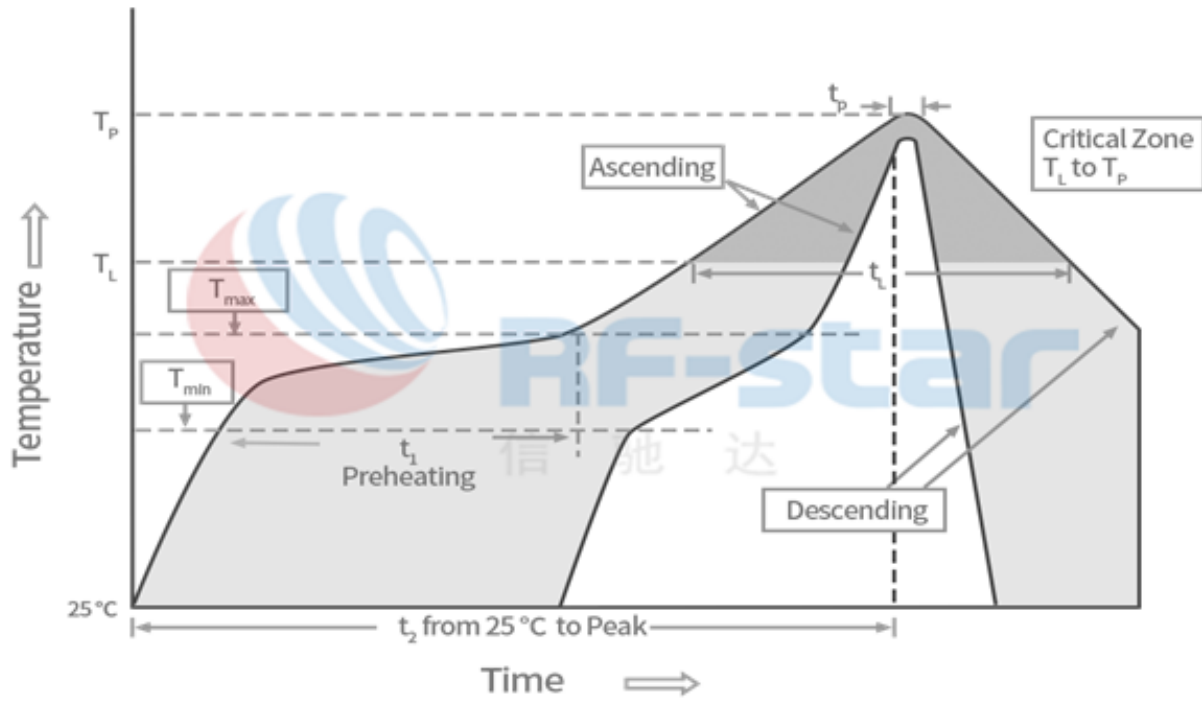

Figure 11. Recommended Reflow for Lead-Free Solder

5 Optional Package Specification

The default package method is **by tray**. If you need the modules to be shipped by tape & reel, pls contact us in advance.

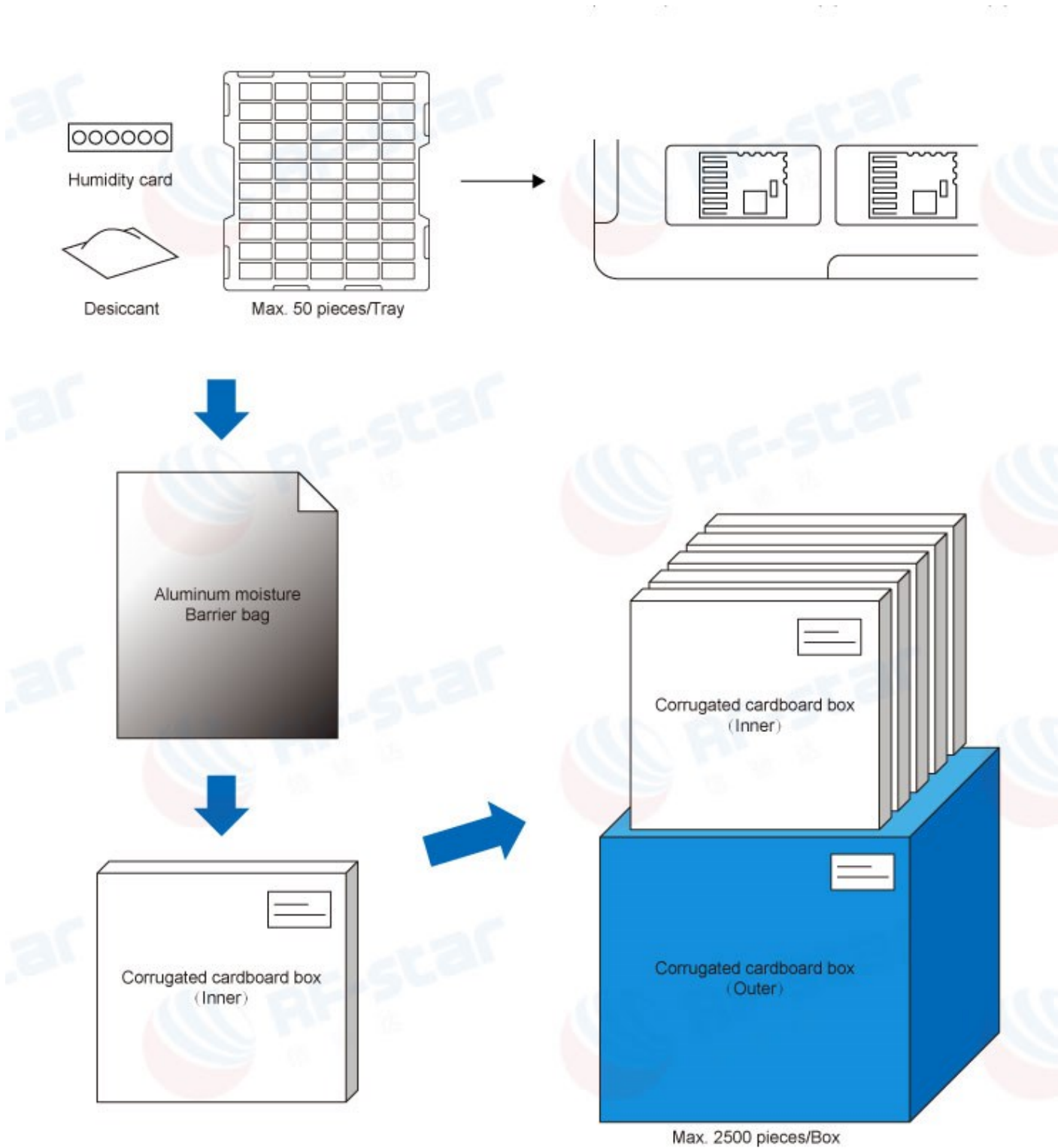

Figure 12. Default Package by Tray

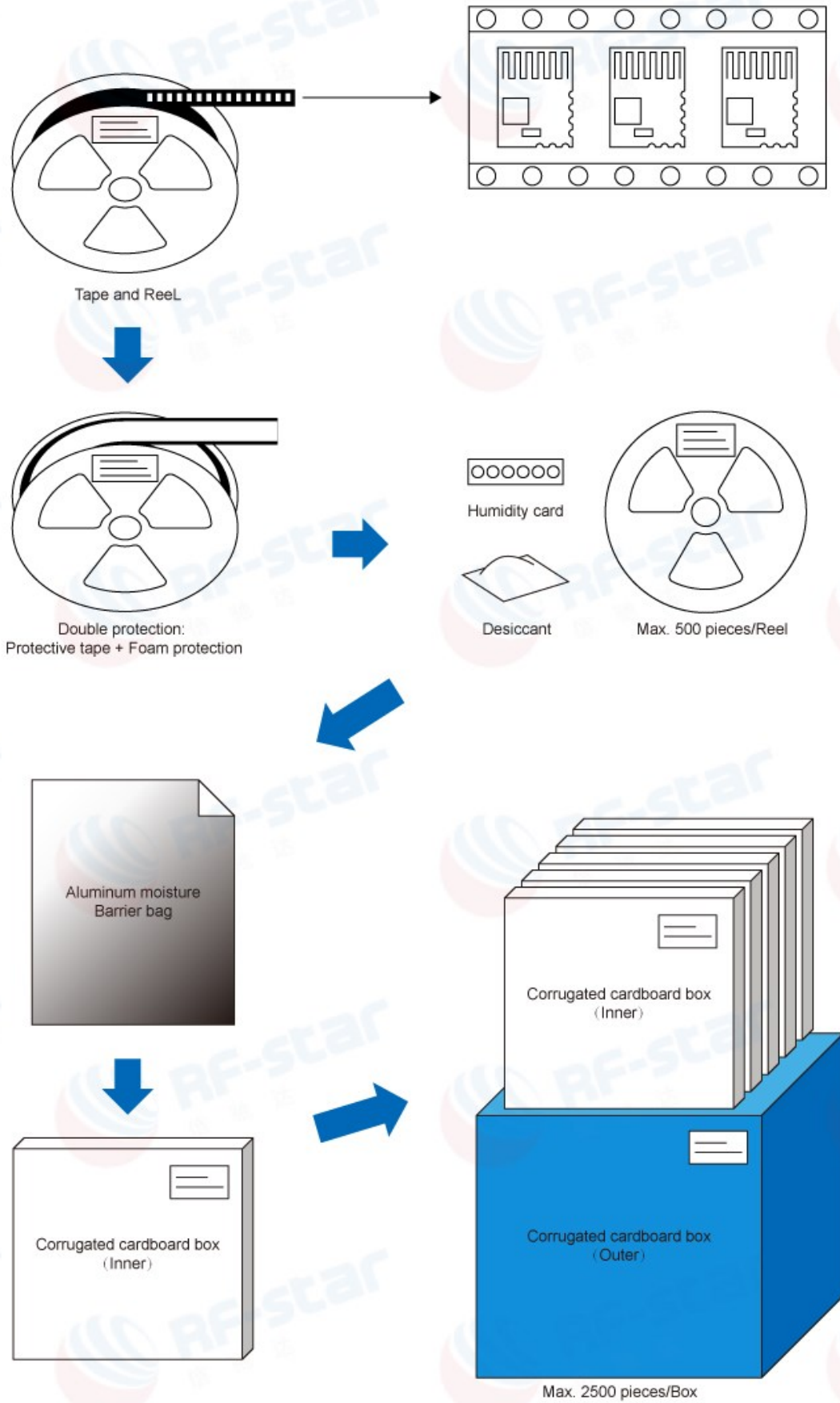

Figure 13. Package by Tape & Reel

6 Certificate

6.1 FCC

This device complies with part 15 of the FCC Rules. Operation is subject to the following two conditions: (1) This device may not cause harmful interference, and (2) this device must accept any interference received, including interference that may cause undesired operation.

FCC ID: 2ABN2-BM2652P2

TCB
GRANT OF EQUIPMENT AUTHORIZATION
TCB

Certification Issued Under the Authority of the Federal Communications Commission

By: Compliance Testing, LLC
1724 S. Nevada Way
Mesa, AZ 85204

Date of Grant: 07/22/2022
Application Dated: 07/22/2022

Shenzhen RF-STAR Technology Co., Ltd
2F, BLDG. 8, Zone A, BaoAn Internet Industry Base,
Bao Yuan Road, Xixiang, BaoAn DIST,
Shenzhen,
China

Attention: Aroo woo

NOT TRANSFERABLE
EQUIPMENT AUTHORIZATION is hereby issued to the named GRANTEE, and is VALID ONLY for the equipment identified hereon for use under the Commission's Rules and Regulations listed below.

FCC IDENTIFIER: 2ABN2-BM2652P2
Name of Grantee: Shenzhen RF-STAR Technology Co., Ltd
Equipment Class: Digital Transmission System
Notes: BT module
Modular Type: Single Modular

Grant Notes	FCC Rule Parts	Frequency Range (MHz)	Output Watts	Frequency Tolerance	Emission Designator
15C	15C	2402.0 - 2480.0	0.0288653		
15C	15C	2405.0 - 2480.0	0.0300677		
15C	15C	2405.0 - 2480.0	0.0287972		

Power output listed is conducted. The module grantee is responsible for providing the documentation to the system integrator on restrictions of use, for continuing compliance of the module. The integrator installing this module into their product must ensure that the final composite product complies with the FCC requirements by a technical assessment or evaluation to the FCC rules, including the transmitter operation and should refer to guidance in FCC 47CFR 15.209. Separate approval is required for all other operating configurations, including portable configurations with respect to 2.1093 and different antenna configurations.

Figure 14. FCC certificate of RF-BM-2652P2(I)

6.2 CE

Declaration of Conformity

The submitted sample of the following equipment has been tested for CE marking according to the following European Directive: the RED Directive 2014/53/EU.

Applicant name & address: Shenzhen RF-star Technology Co., Ltd.
Room 601, Block C, Skyworth Building, High-tech Park, Nanshan District, Shenzhen, Guangdong, China

Manufacturer name & address: Shenzhen RF-star Technology Co., Ltd.
Room 601, Block C, Skyworth Building, High-tech Park, Nanshan District, Shenzhen, Guangdong, China

Product: BT module
Model/Type reference: RF-BM-2652P2 - RF-BM-2652P2(I)

Trade mark: RF-STAR

Order No.: BLA-EMC-202107-4136

Essential Requirements	Applied Specifications/Standards	Documentary Evidence
Art 3.1 (a) Health	EN 62479-2:2010	Test Report BLA-EMC-202107-413604
Art 3.1 (a) Safety	EN IEC 62368-1: 2020	Test Report BLA-S-202107-4311
Art 3.1 (b) EMC	ETSI EN 301 489-1 V2.2.3 (2019-11); ETSI EN 301 489-17 V3.2.4 (2020-09)	Test Report BLA-EMC-202107-413601
Art 3.2 Radio	ETSI EN 300328 V2.2.2 (2019-07)	Test Report BLA-EMC-202107-413602 BLA-EMC-202107-413603

This verification has been granted to the applicant based on the results of the tests performed by laboratory of Beitiao of Technical Services (Beitiao) Co., Ltd on the sample of the abovementioned product in accordance with the provisions of the relevant specific standards and the product is in conformity with the essential requirements of Article 3.1 (a) (i) 3.2 of Directive 2014/53/EU. The CE mark is shown below and can be used, under the responsibility of the manufacturer, after consultation of the CE mark.

Blue Zhong
Quality Engineer
Date: 2021/8/30

Bureau of Technical Services (Beitiao) Co., Ltd
Building C, No. 107, Shihua Road, Shiyao Sub-District, Baoan District,
Shenzhen, Guangdong Province, China
Tel: +86-755-32928482
Email: market@beitiao.com
www.beitiao.com

Figure 15. CE certificate of RF-BM-2652P2(I)

7 Revision History

Date	Version No.	Description
2020.07.09	V1.0	The initial version is released.
2022.07.11	V1.1	Add the antenna part. Add the certificates.
2022.12.06	V1.1	Add the PA output Control Chapter.
2023.05.25	V1.1	Update MSL level. Update the Shenzhen office address.
2024.01.23	V1.1	Update the Recommended PCB Footprint of RF-BM-2652P4(I). Update the Antenna Output Mode Modification.

Note:

1. The document will be optimized and updated from time to time. Before using this document, please make sure it is the latest version.
2. To obtain the latest document, please download it from the official website: www.rfstariot.com and www.szrfstar.com.

8 Contact Us

SHENZHEN RF-STAR TECHNOLOGY CO., LTD.

Shenzhen HQ:

Add.: Room A503, Podium Building No. 12, Shenzhen Bay Science and Technology Ecological Park, Nanshan District, Shenzhen, Guangdong, China, 518063

Tel.: 86-755-8632 9829

Chengdu Branch:

Add.: N2-1604, Global Center, North No. 1700, Tianfu Avenue, Hi-Tech District, Chengdu, Sichuan, China, 610095

Tel.: 86-28-8692 5399

Email: sunny@szrfstar.com, sales@szrfstar.com

Web.: www.rfstariot.com, www.szrfstar.com

