



RF-BM-2340T3 CC2340R5
BLE 5.3 or ZigBee 3.0 Wireless Module

Version 1.0

Shenzhen RF-star Technology Co., Ltd.

Jan. 2nd, 2024

All rights reserved. Those responsible for unauthorized reproduction will be prosecuted.

1 Device Overview

1.1 Description

RF-BM-2340T3 is an RF module based on TI lower-power CC2340R5 SoC. It is a multiprotocol 2.4 GHz wireless module supporting Thread, ZigBee®, Bluetooth® 5.3 Low Energy, IEEE 802.15.4, and proprietary 2.4 GHz. The module integrates a 48 MHz crystal, 512 kB of in-system Programmable Flash, 12 kB ROM for bootloader, and 64 kB of ultra-low leakage SRAM. The ARM® Cortex®-M0+ core application processor can operate at an extremely low current at flexible power modes. The module enables long-range and low-power applications using 8 dBm high-power with best-in-class transmit current consumption at 12 mA. It features a small size, robust connection distance, and rigid reliability. The 1.27-mm half-hole pitch stamp stick makes the module more convenient for application and development. RF-BM-2340T3 is embedded with a high-performance onboard PCB antenna. The UART serial port protocol can also enable you to start your development with a quick path.

1.2 Key Features

- RF Features
 - Bluetooth® 5.3 Low Energy
 - Bluetooth Mesh (Low power node)
 - ZigBee®
 - Thread
 - Proprietary
- TX power: up to +8 dBm with temperature compensation
- Excellent receiver sensitivity
 - -102 dBm for Bluetooth 125 kbps (LE coded PHY)
 - -99 dBm for Bluetooth 500 kbps (LE coded PHY)
 - -96.5 dBm for Bluetooth 1 Mbps
 - -92 dBm for Bluetooth 2 Mbps
- Wide Operation Range
 - Power supply:
 - ◇ GLDO mode: 1.71 V ~ 3.8 V, recommend to 3.3 V
 - ◇ DCDC mode: 2.2 V ~ 3.8 V, recommend to 3.3 V
 - Operating temperature: -40 °C to +85 °C
 - Storage temperature: -40 °C to +125 °C
 - Frequency range: 2360 MHz ~ 2510 MHz
- Microcontroller
 - Powerful 48 MHz ARM® Cortex®-M0+ processor
 - Integrated Balun
 - Support OTA upgrade
- Memory
 - 512 kB of in-system programmable flash
 - 12 kB of ROM for bootloader and drivers
 - 64 kB of ultra-low leakage SRAM. Retained in standby mode
- Rich Peripherals
 - 11 IO Pads
 - ◇ 2 IO pads SWD, muxed with GPIOs
 - ◇ Up to 9 DIOs (analog or digital IOs)
 - 3 × 16-bit or 1 × 24-bit general-purpose timers, Quadrature decode mode support
 - 12-bit ADC, 1.2 Msps with external reference, 267 kbps with internal reference, up to 12 external ADC inputs
 - 1 × low power comparator
 - 1 × UART
 - 1 × SPI
 - 1 × I²C
 - Real-time clock (RTC)
 - Integrated temperature and battery monitor

- Watchdog timer
- Security Enablers
 - AES 128-bit Crypto accelerator
 - Random number generator from on-chip
- analog noise
- Dimension:
 - RF-BM-2340T3: 15.0 mm × 15.0 mm × 2.0 mm

1.3 Applications

- Home healthcare
- Blood glucose monitors
- Blood pressure monitor
- CPAP machine
- Electronic thermometer
- Patient monitoring & diagnostics
- Medical sensor patches
- Personal care & Fitness
- Electric toothbrush
- Wearable fitness & activity monitor
- Building automation
- Building security systems
- Motion detector
- Electronic smart lock
- Door and window sensor
- Garage door system
- Gateway
- HVAC
- Thermostat
- Wireless environmental sensor
- Fire safety system
- Smoke and heat detector
- Video surveillance
- IP network camera
- Lighting
- LED luminaire
- Lighting Control
- Daylight sensor, lighting sensor
- Wireless control
- Factory automation and control
- Retail automation & payment
- Electronic point of sale
- Communication equipment
- Wired networking
- Personal electronics
- Connected peripherals
- Consumer wireless module
- Pointing devices
- Keyboards and keypads
- Gaming
- Electronic and robotic toys
- Wearables (non-medical)
- Smart trackers
- Smart clothing

1.4 Functional Block Diagram

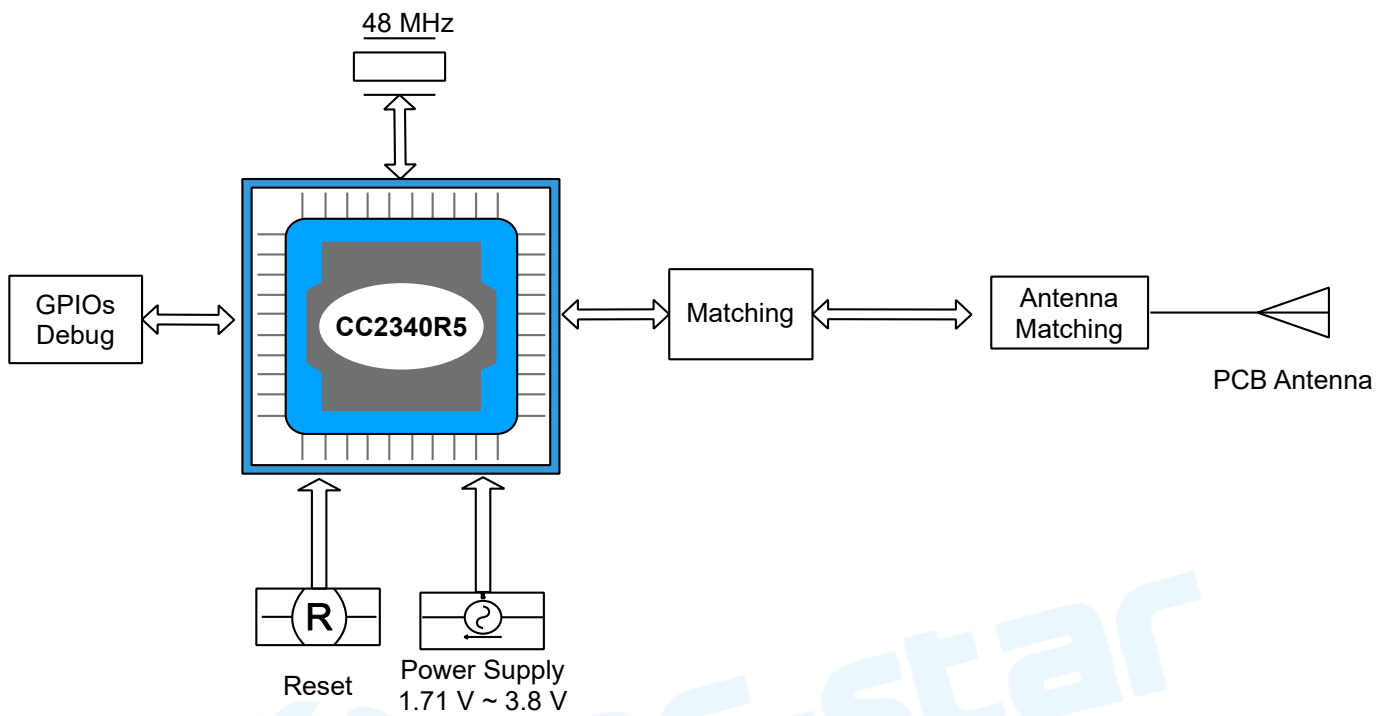

Figure 1. Functional Block Diagram of RF-BM-2340T3

1.6 Part Number Conventions

The part numbers are of the form of RF-BM-2340T3 where the fields are defined as follows:

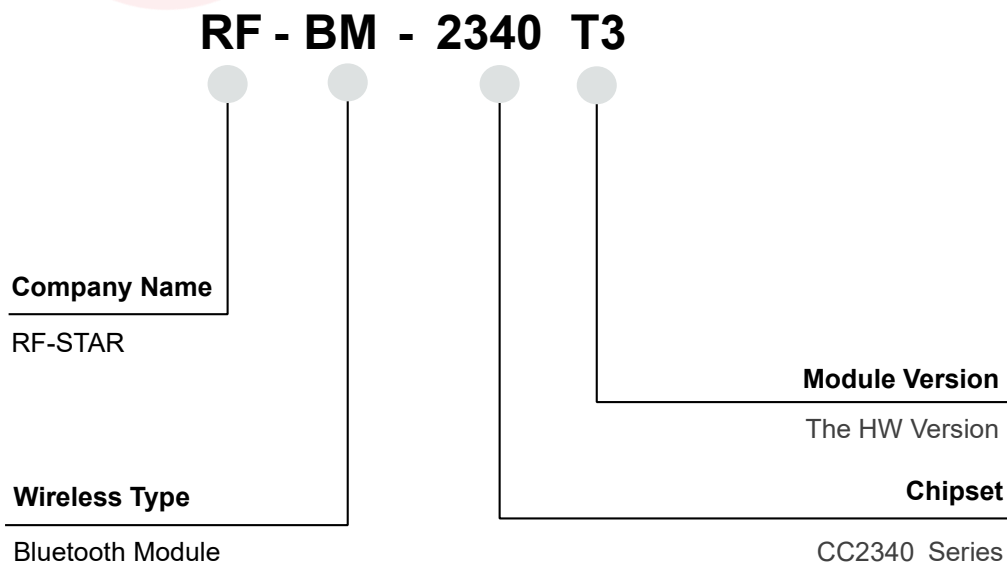

Figure 2. Part Number Conventions of RF-BM-2340T3

Table of Contents

1 Device Overview	2
1.1 Description.....	2
1.2 Key Features	2
1.3 Applications.....	3
1.4 Functional Block Diagram	4
1.6 Part Number Conventions	4
Table of Contents.....	5
2 Module Configuration and Functions	6
2.1 Module Parameters.....	6
2.2 Module Pin Diagram	7
2.3 Pin Functions.....	7
2.4 Pin Peripheral Singal Descriptions.....	8
3 Specifications	10
3.1 Recommended Operating Conditions	10
3.2 Handling Ratings.....	10
4 Internal 32.768 kHz Crystal Setting	11
5 Application, Implementation, and Layout.....	12
5.1 Module Photos	12
5.2 Recommended PCB Footprint.....	12
5.3 Schematic Diagram.....	13
5.4 Antenna.....	13
5.4.1 Antenna Design Recommendation	13
5.6 Basic Operation of Hardware Design	14
5.7 Trouble Shooting.....	15
5.7.1 Unsatisfactory Transmission Distance.....	15
5.7.2 Vulnerable Module.....	15
5.7.3 High Bit Error Rate	15
5.8 Electrostatics Discharge Warnings	16
5.9 Soldering and Reflow Condition.....	16
6 Optional Package Specification	18
7 Revision History	20
8 Contact Us.....	21

2 Module Configuration and Functions

2.1 Module Parameters

Table 1. Parameters of RF-BM-2340T3

Chipset	CC2340R5
Supply Power Voltage	DCDC mode: 2.2 V ~ 3.8 V, 3.3 V is recommended GLDO mode: 1.71 V ~ 3.8 V, 3.3 V is recommended Remark: When set to DCDC mode, if the supply voltage is lower than 2.2 V, it will automatically switch to GLDO mode.
Frequency	2360 MHz ~ 2510 MHz
Maximum Transmit Power	+8.0 dBm
Receiving Sensitivity	-102 dBm @ Bluetooth 125 kbps (LE Coded PHY) -99 dBm @ Bluetooth 500 kbps (LE Coded PHY) -96.5 dBm @ Bluetooth 1 Mbps -92 dBm @ Bluetooth 2 Mbps
GPIO	11
Flash	512 kB
ROM	12 kB for bootloader and drivers
SRAM	64 kB
Power Consumption	RX current: 5.3 mA TX current: 5.1 mA @ 0 dBm < 11.0 mA @ 8 dBm MCU (CoreMark): 2.6 mA @ active mode Standby: < 710 nA @RTC, 36 KB RAM Shutdown: 150 nA @ wake-up on pin
Support Protocol	Bluetooth 5.3 Low Energy, ZigBee, Proprietary, SimpleLink TI 15.4-stack
Crystal	48 MHz
Package	SMT packaging (1.27-mm half-hole pitch stamp stick)
Dimension	15.0 mm × 15.0 mm × 2.0 mm
Type of Antenna	PCB antenna
Operating Temperature	-40 °C ~ +85 °C
Storage Temperature	-40 °C ~ +125 °C

2.2 Module Pin Diagram

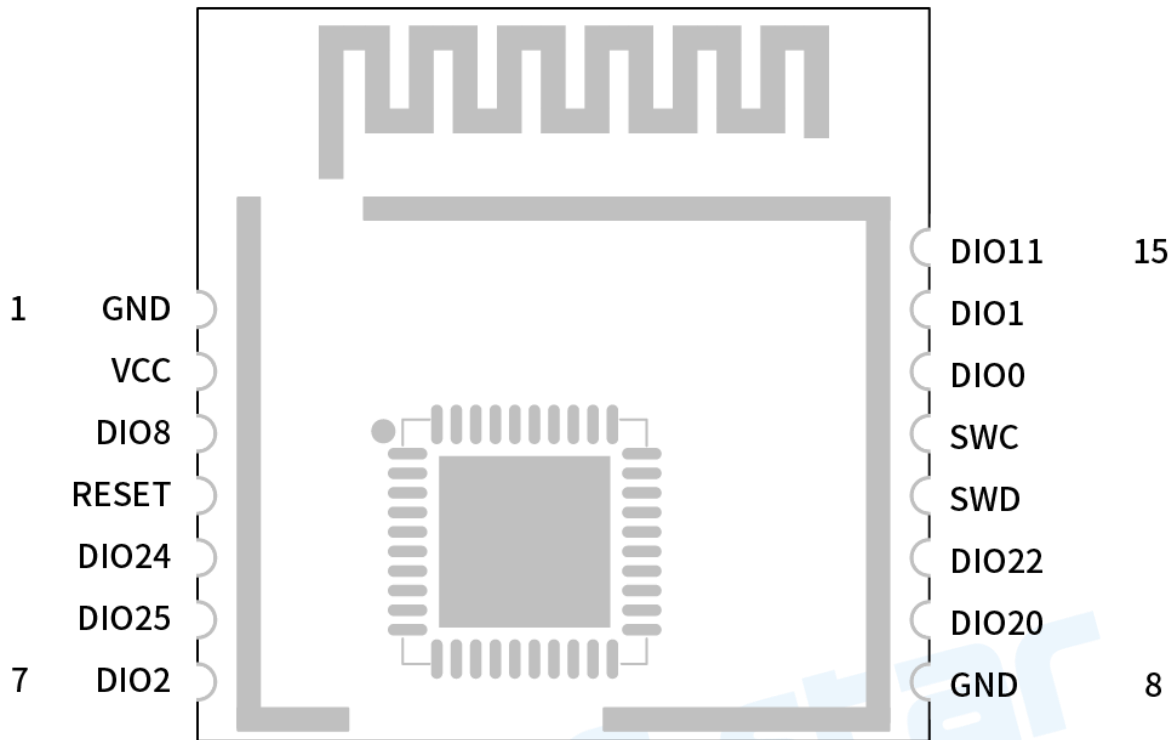

Figure 3. Pin Diagram of RF-BM-2340T3

2.3 Pin Functions

Table 2. Pin Functions of RF-BM-2340T3

Pin	Name	Chip Pin	Function	Description
1	GND	GND	Ground	Ground
2	VCC	VCCS	VCC	Power supply: 1.71 V ~ 3.8 V, recommended to 3.3 V
3	DIO8	DIO8	Digital	GPIO
4	RESET	RSTN	Digital	Reset, active low. Internal pullup.
5	DIO24	DIO24_A7	Digital or Analog	GPIO, analog capability, high-drive capability
6	DIO25	DIO25_A6	Digital or Analog	GPIO, analog capability
7	DIO2	DIO2_A3	Digital or Analog	GPIO, analog capability
8	GND	GND	Ground	Ground
9	DIO20	DIO20_A11	Digital or Analog	GPIO, analog capability
10	DIO22	DIO22_A9	Digital or Analog	GPIO, analog capability
11	SWD	DIO17_SWDCCK	Digital	GPIO, SWD interface: clock(JTAG_TCKC), high-drive capability
12	SWC	DIO16_SWDIO	Digital	GPIO, SWD interface: mode select or SWDIO

				(JTAG_TMSC), high-drive capability
13	DIO0	DIO0_A5	Digital or Analog	GPIO, analog capability
14	DIO1	DIO1_A4	Digital or Analog	GPIO, analog capability
15	DIO11	DIO11	Digital	GPIO

2.4 Pin Peripheral Singal Descriptions

Table 3. Pin Peripheral Singal Description of RF-BM-2340T3

Function	Singal Name	Module Pin	Chip Pin	Signal Direction	Description
UART	UART0TXD	DIO17	DIO17_SWDCCK	O	UART0 RX data
		DIO20	DIO20_A11		
	UART0RXD	DIO16	DIO16_SWDIO	I	UART0 TX data
		DIO20	DIO20_A11		
		DIO22	DIO22_A9		
	UART0CTS	DIO2	DIO2_A3	I	UART0 clear-to-send input (active low)
UART0RTS	DIO8	DIO8	O	UART0 request-to-send (active low)	
	DIO1	DIO1_A4			
ADC	ADC11	DIO20	DIO20_A11	I	HP ADC channel 11 input
	ADC9	DIO22	DIO22_A9		HP ADC channel 9 input
	ADC5	DIO0	DIO0_A5		ADC channel 5 input
	ADC3	DIO2	DIO2_A3		ADC channel 3 input

Table 4. Pin Peripheral Singal Description of RF-BM-2340T1/T2 (Continued 1)

Function	Singal Name	Module Pin	Chip Pin	Signal Direction	Description
SPI	SPI0SCLK	DIO8	DIO8	I/O	SPI clock
		DIO17	DIO17_SWDCCK		
		DIO24	DIO24_A7		
	SPI0POCI	DIO11	DIO11	I/O	SPI POCI (MISO)
		DIO20	DIO20_A11		
	SPI0CSN	DIO11	DIO11	I/O	SPI chip select
		DIO0	DIO0_A5		
SPI0PICO	DIO16	DIO16_SWDIO	I/O	SPI PICO (MOSI)	

I²C	I2C0SCL	DIO17	DIO17_SWDCCK	I/O	I ² C clock data
		DIO24	DIO24_A7		
	I2C0SDA	DIO8	DIO8	I/O	I ² C data
		DIO16	DIO16_SWDIO		
DIO0		DIO0_A5			
GPIO	GPIO8	DIO8	DIO8	I/O	General-purpose input or output
	GPIO11	DIO11	DIO11		
	GPIO16	DIO16	DIO16_SWDIO		
	GPIO17	DIO17	DIO17_SWDCCK		
	GPIO20	DIO20	DIO20_A11		
	GPIO22	DIO22	DIO22_A9		
	GPIO24	DIO24	DIO24_A7		
	GPIO0	DIO0	DIO0_A5		
	GPIO2	DIO2	DIO2_A3		

3 Specifications

3.1 Recommended Operating Conditions

The functional operation does not guarantee performance beyond the limits of the conditional parameter values in the table below. Long-term work beyond this limit will affect the reliability of the module more or less.

Table 5. Recommended Operating Conditions of RF-BM-2340T3

Items	Condition	Min.	Typ.	Max.	Unit
Operating Supply Voltage	/	1.71	3.3	3.8	V
Operating Temperature	/	-40	+25	+85	°C

3.2 Handling Ratings

Table 6. Handling Ratings of RF-BM-2340T3

Items	Condition	Min.	Typ.	Max.	Unit
Storage Temperature	Tstg	-40	+25	+125	°C
Human Body Model	HBM		±1000		V
Moisture Sensitivity Level			3		
Charged Device Model			±500		V

4 Internal 32.768 kHz Crystal Setting

The module hardware is without an external 32.768 kHz crystal by default. However, the SDK adopts the external 32.768 kHz crystal by default, pls see the details below:

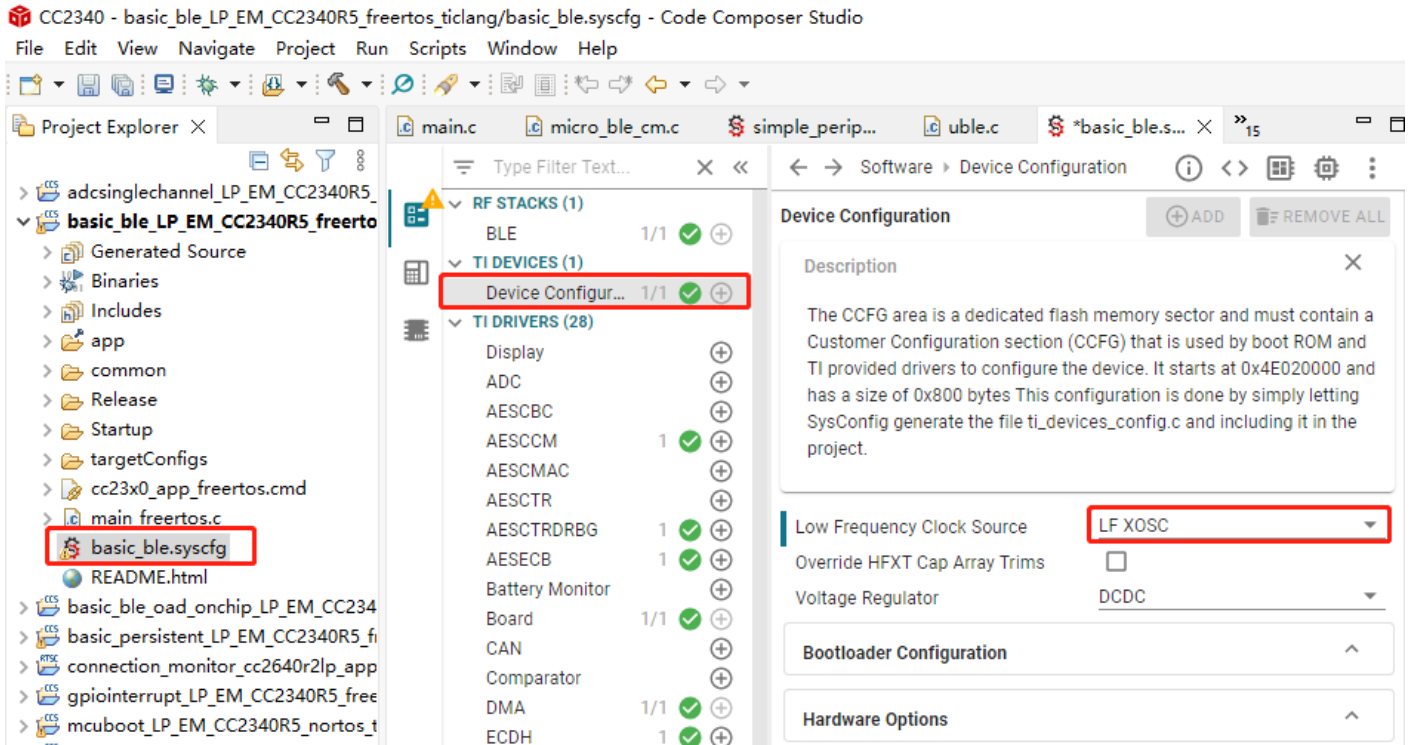

Therefore, in order no problem during debugging, pls modify the default crystal setting to the internal crystal LFRCOS as follows:

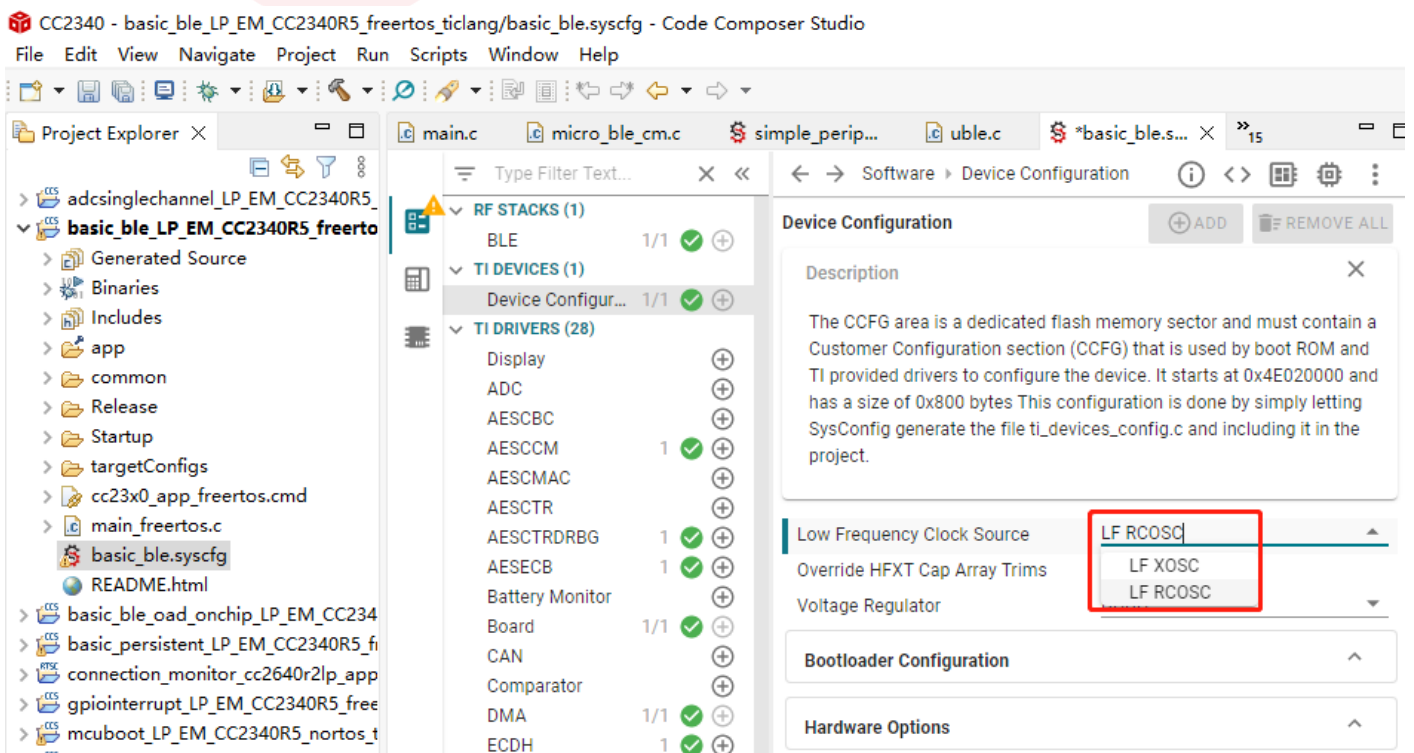

5 Application, Implementation, and Layout

5.1 Module Photos

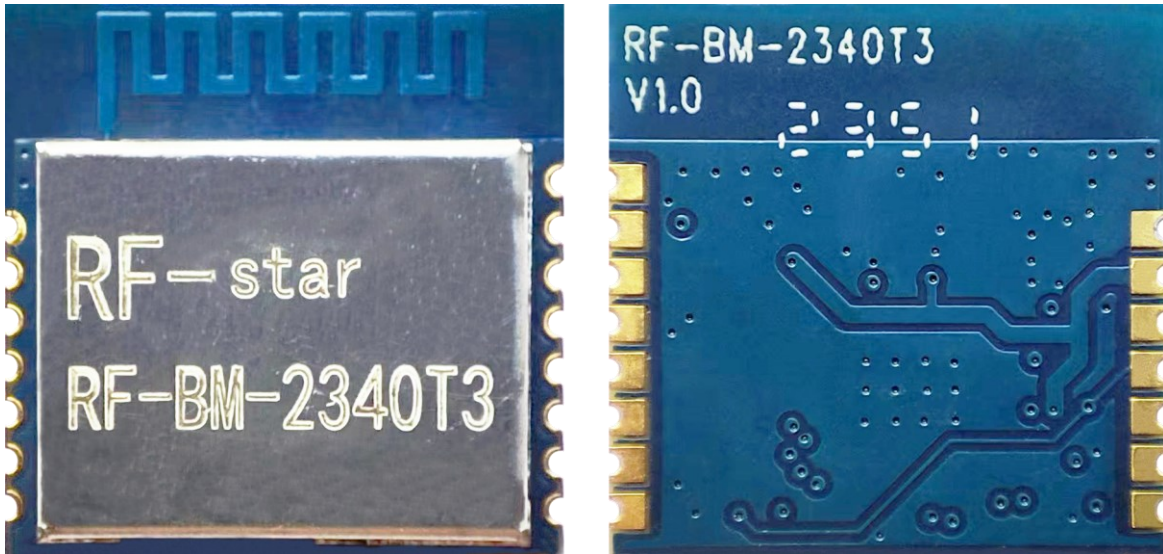

Figure 3. Photos of RF-BM-2340T3

5.2 Recommended PCB Footprint

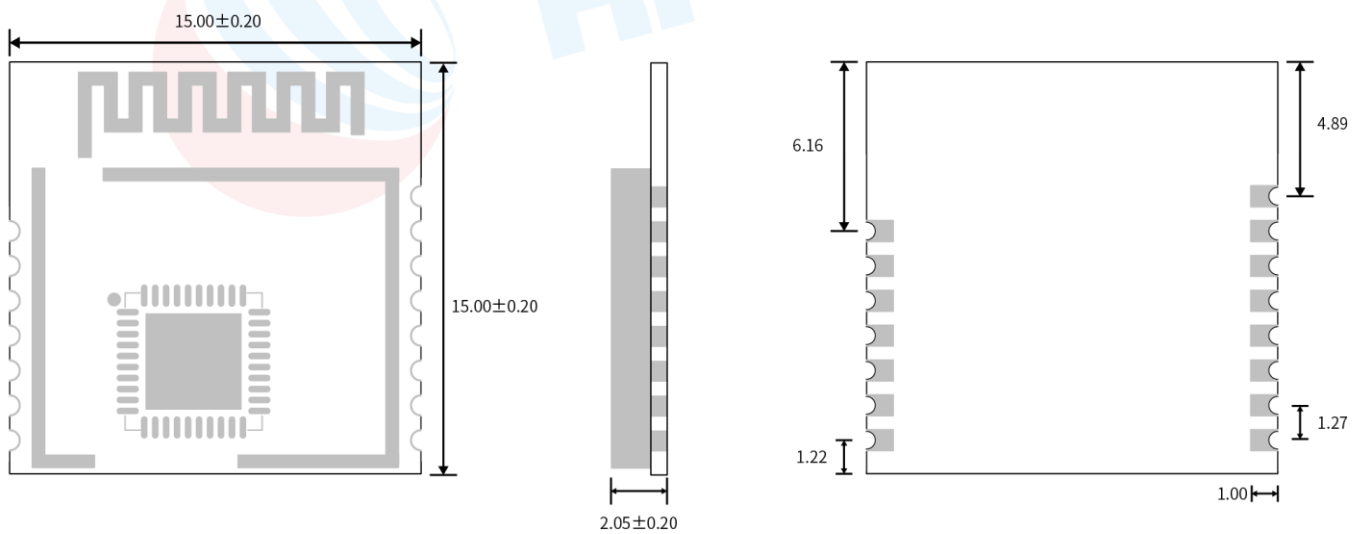

Figure 4. Recommended PCB Footprint of RF-BM-2340T3

5.3 Schematic Diagram

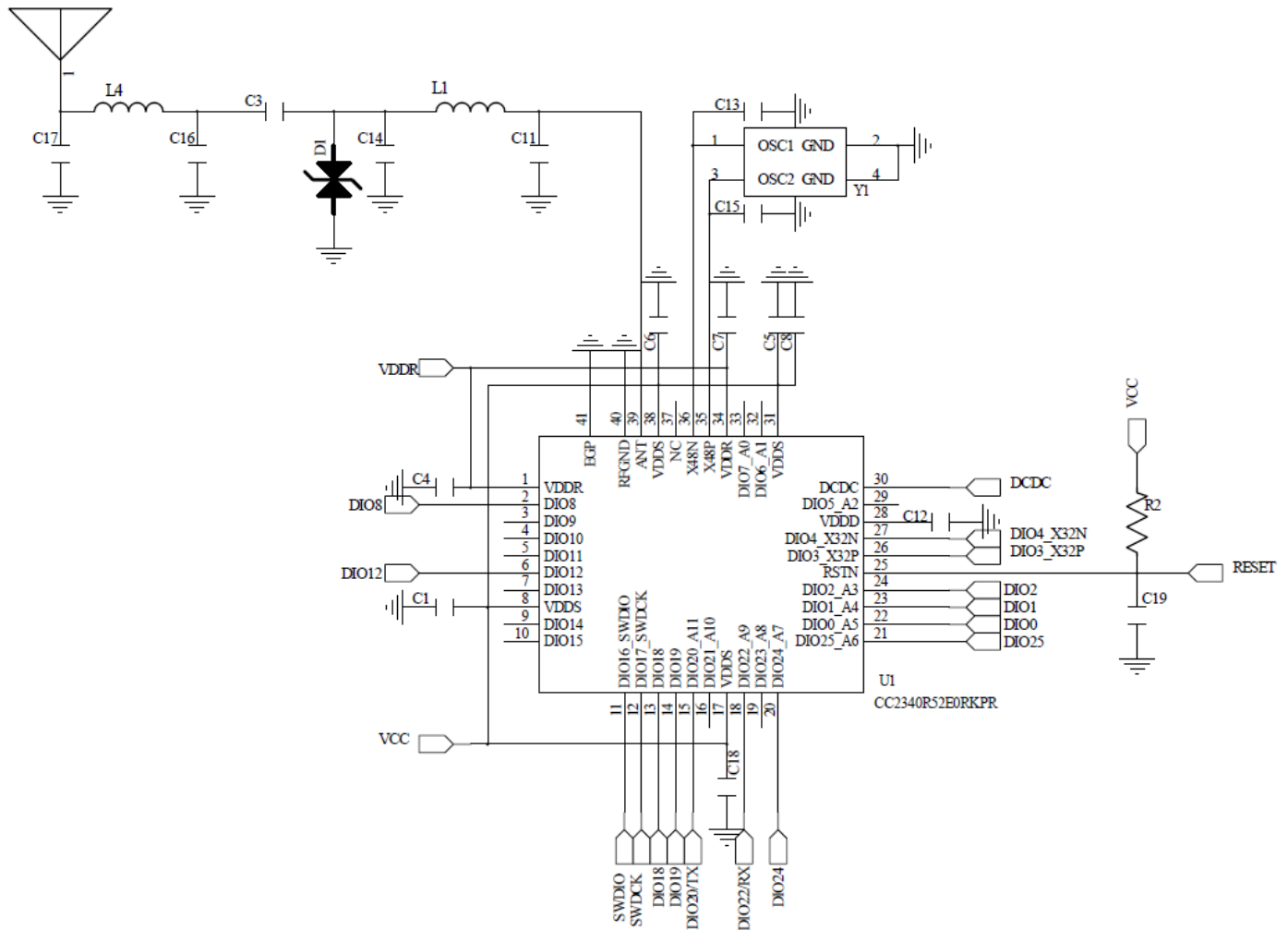

Figure 5. Schematic Diagram of RF-BM-2340T3

5.4 Antenna

5.4.1 Antenna Design Recommendation

1. The antenna installation structure has a great influence on the module performance. It is necessary to ensure the antenna is exposed and preferably vertically upward. When the module is installed inside of the case, a high-quality antenna extension wire can be used to extend the antenna to the outside of the case.
2. The antenna must not be installed inside the metal case, which will cause the transmission distance to be greatly weakened.
3. The recommendation of antenna layout.

The inverted-F antenna position on PCB is free-space electromagnetic radiation. The location and layout of the antenna are key factors to increase the data rate and transmission range.

Therefore, the layout of the module antenna location and routing is recommended as follows:

- (1) Place the antenna on the edge (corner) of the PCB.
- (2) Make sure that there is no signal line or copper foil in each layer below the antenna.
- (3) It is best to hollow out the antenna position in the following figure to ensure that the S11 of the module is minimally affected.

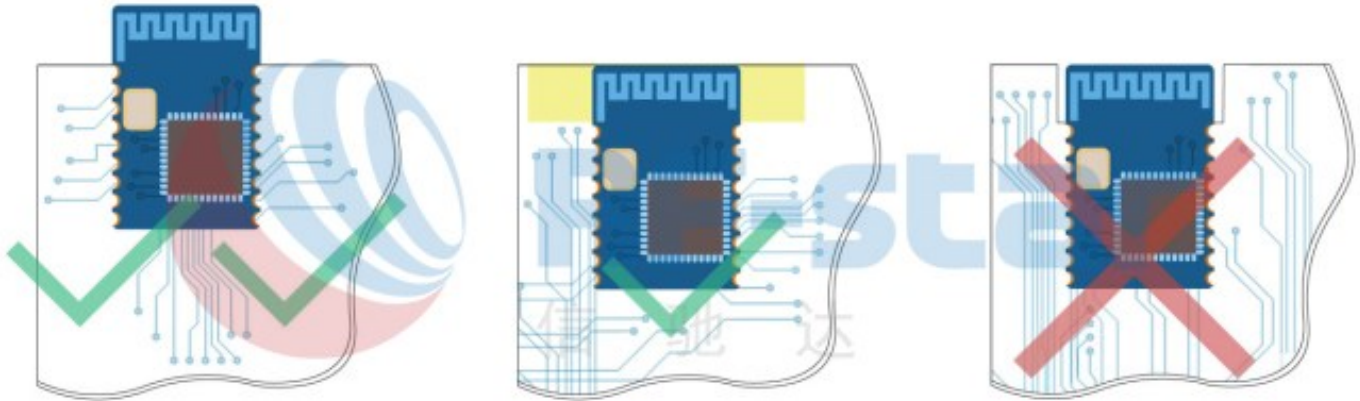

Figure 4. Recommendation of Antenna Layout

Note: The hollow-out position is based on the antenna used.

5.6 Basic Operation of Hardware Design

1. It is recommended to offer the module a DC stabilized power supply, a tiny power supply ripple coefficient, and reliable ground. Please pay attention to the correct connection between the positive and negative poles of the power supply. Otherwise, the reverse connection may cause permanent damage to the module.
2. Please ensure the supply voltage is between the recommended values. The module will be permanently damaged if the voltage exceeds the maximum value. Please ensure a stable power supply and no frequently fluctuating voltage.
3. When designing the power supply circuit for the module, it is recommended to reserve more than 30% of the margin, which is beneficial to the long-term stable operation of the whole machine. The module should be far away from the power electromagnetic, transformer, high-frequency wiring, and other parts with large electromagnetic interference.
4. The bottom of the module should avoid high-frequency digital routing, high-frequency analog routing, and power routing. If it has to route the wire on the bottom of the module, for example, it is assumed that the module is soldered to the Top Layer, the copper must be spread on the connection part of the top layer and the module, and be close to the digital part of the module and routed in the Bottom Layer (all copper is well-grounded).
5. Assuming that the module is soldered or placed in the Top Layer, it is also wrong to randomly route the Bottom Layer or other layers, which will affect the spurs and receiving sensitivity of the module to some degree.
6. Assuming that there are devices with large electromagnetic interference around the module, which will greatly affect the module performance. It is recommended to stay away from the module according to the strength of the interference. If circumstances permit, appropriate isolation and shielding can be done.

7. Assuming that there are routings of large electromagnetic interference around the module (high-frequency digital, high-frequency analog, power routings), which will also greatly affect the module performance. It is recommended to stay away from the module according to the strength of the interference. If circumstances permit, appropriate isolation and shielding can be done.
8. It is recommended to stay away from the devices whose TTL protocol is the same 2.4 GHz physical layer, for example, USB 3.0.

5.7 Trouble Shooting

5.7.1 Unsatisfactory Transmission Distance

1. When there is a linear communication obstacle, the communication distance will be correspondingly weakened. Temperature, humidity, and co-channel interference will lead to an increase in the communication packet loss rate. The performances of ground absorption and reflection of radio waves will be poor when the module is tested close to the ground.
2. Seawater has a strong ability to absorb radio waves, so the test results by the seaside are poor.
3. The signal attenuation will be very obvious if there is metal near the antenna or if the module is placed inside the metal shell.
4. The incorrect power register set or the high data rate in the open air may shorten the communication distance. The higher the data rate, the closer the distance.
5. The low voltage of the power supply is lower than the recommended value at ambient temperature, and the lower the voltage, the smaller the power is.
6. The unmatchable antennas and modules or the poor quality of antenna will affect the communication distance.

5.7.2 Vulnerable Module

1. Please ensure the supply voltage is between the recommended values. The module will be permanently damaged if the voltage exceeds the maximum value. Please ensure a stable power supply and no frequently fluctuating voltage.
2. Please ensure the anti-static installation and the electrostatic sensitivity of high-frequency devices.
3. Due to some humidity-sensitive components, please ensure the suitable humidity during installation and application. If there is no special demand, it is not recommended to use at too high or too low temperature.

5.7.3 High Bit Error Rate

1. There are co-channel signal interferences nearby. It is recommended to be away from the interference sources or modify the frequency and channel to avoid interferences.
2. The unsatisfactory power supply may also cause garbled. It is necessary to ensure the power supply's reliability.

- If the extension wire or feeder wire is of poor quality or too long, the bit error rate will be high.

5.8 Electrostatics Discharge Warnings

The module will be damaged by the discharge of static. RF-star suggests that all modules should follow the 3 precautions below:

- According to the anti-static measures, bare hands are not allowed to touch modules.
- Modules must be placed in anti-static areas.
- Take the anti-static circuitry (when inputting HV or VHF) into consideration in product design.

Static may result in the degradation in performance of the module, even causing failure.

5.9 Soldering and Reflow Condition

- Heating method: Conventional Convection or IR/convection.
- Solder paste composition: Sn96.5/Ag3.0/Cu0.5
- Allowable reflow soldering times: 2 times based on the following reflow soldering profile.
- Temperature profile: Reflow soldering shall be done according to the following temperature profile.
- Peak temperature: 245 °C.

Table 7. Temperature Table of Soldering and Reflow

Profile Feature	Sn-Pb Assembly	Pb-Free Assembly
Solder Paste	Sn63 / Pb37	Sn96.5 / Ag3.0 / Cu0.5
Min. Preheating Temperature (T_{min})	100 °C	150 °C
Max. Preheating Temperature (T_{max})	150 °C	200 °C
Preheating Time (T_{min} to T_{max}) (t_1)	60 s ~ 120 s	60 s ~ 120 s
Average Ascend Rate (T_{max} to T_p)	Max. 3 °C/s	Max. 3 °C/s
Liquid Temperature (T_L)	183 °C	217 °C
Time above Liquidus (t_L)	60 s ~ 90 s	30 s ~ 90 s
Peak Temperature (T_p)	220 °C ~ 235 °C	230 °C ~ 250 °C
Average Descend Rate (T_p to T_{max})	Max. 6 °C/s	Max. 6 °C/s
Time from 25 °C to Peak Temperature (t_2)	Max. 6 minutes	Max. 8 minutes
Time of Soldering Zone (t_p)	20±10 s	20±10 s

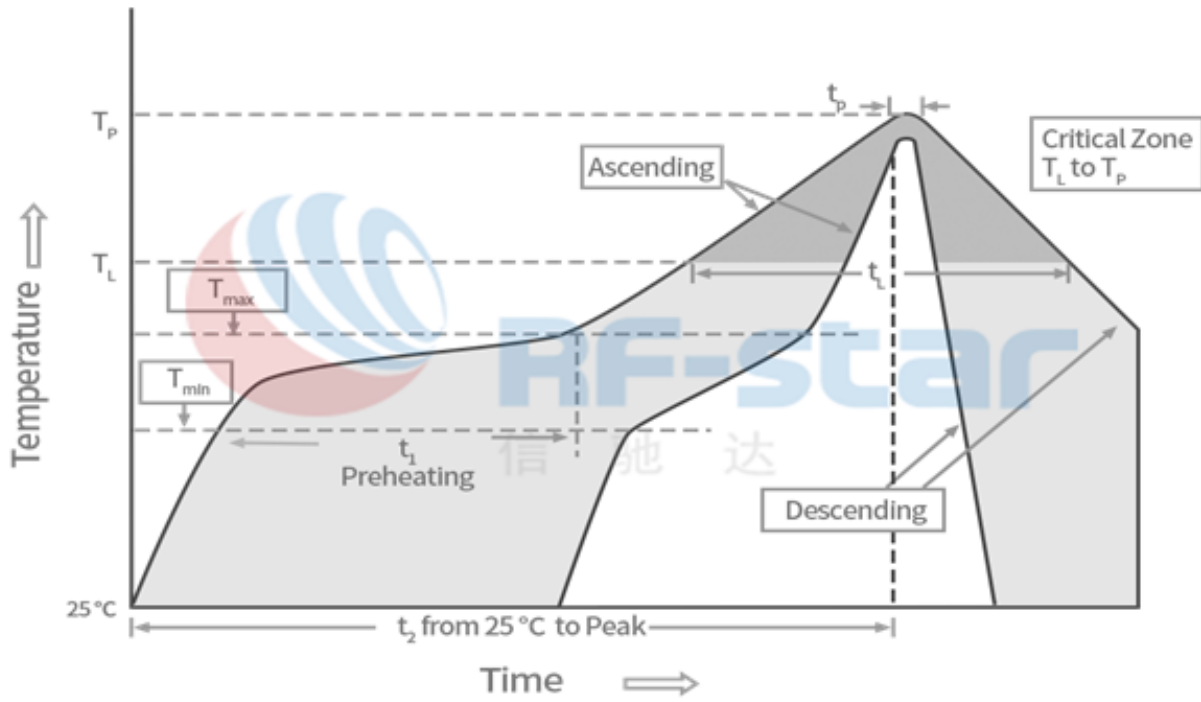

Figure 5. Recommended Reflow for Lead-Free Solder

6 Optional Package Specification

The default package method is **by tray**. If you need the modules to be shipped by tape & reel, pls contact us in advance.

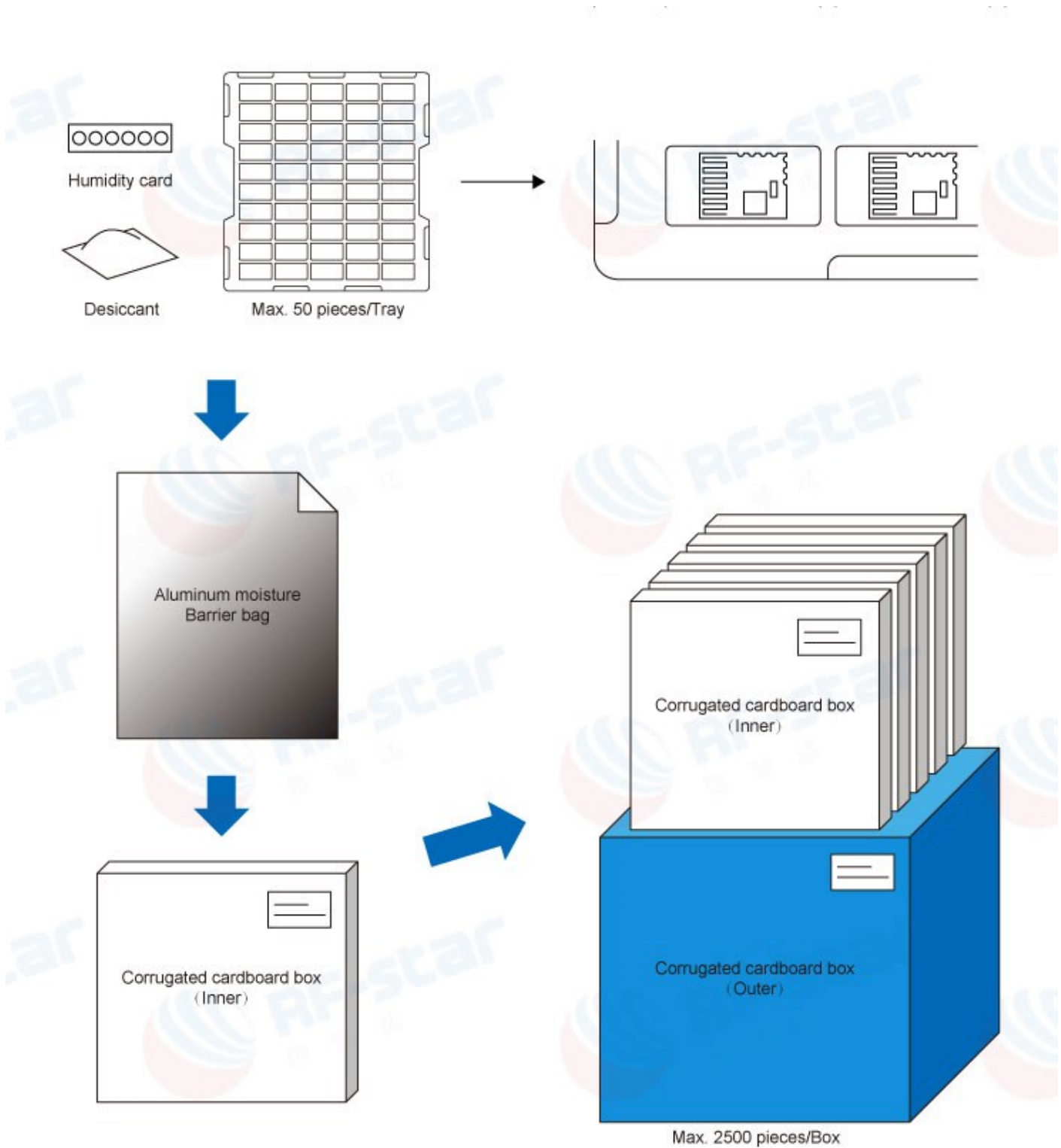

Figure 6. Default Package by Tray

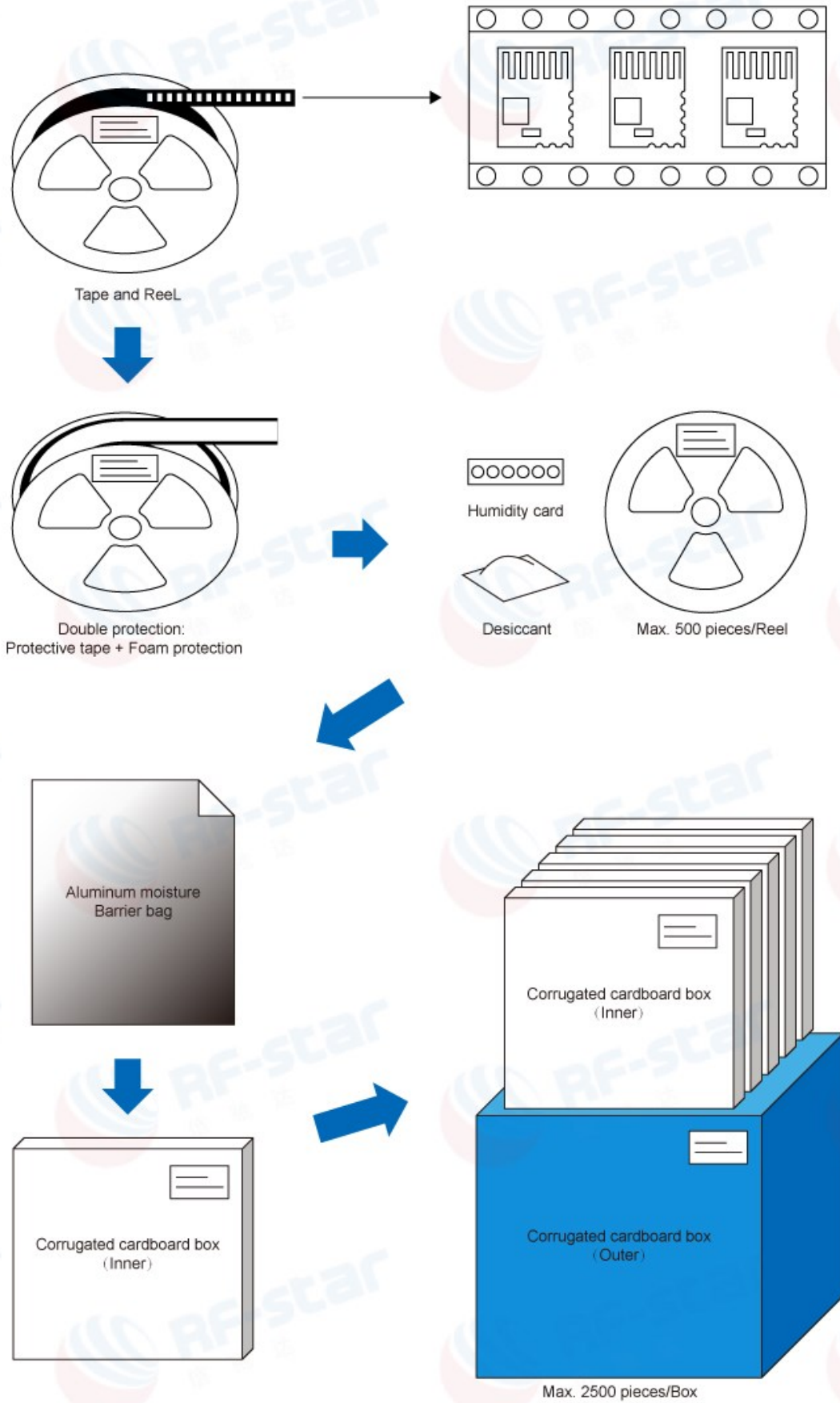

Figure 7. Package by Tape & Reel

7 Revision History

Date	Version No.	Description
2024.01.02	V1.0	The initial version is released.

Note:

1. The document will be optimized and updated from time to time. Before using this document, please make sure it is the latest version.
2. To obtain the latest document, please download it from the official website: www.rfstariot.com and www.szrfstar.com.



8 Contact Us

SHENZHEN RF-STAR TECHNOLOGY CO., LTD.

Shenzhen HQ:

Add.: Room A503, Podium Building No. 12, Shenzhen Bay Science and Technology Ecological Park, Nanshan District, Shenzhen, Guangdong, China, 518063

Tel.: 86-755-8632 9829

Chengdu Branch:

Add.: N2-1604, Global Center, North No. 1700, Tianfu Avenue, Hi-Tech District, Chengdu, Sichuan, China, 610095

Tel.: 86-28-8692 5399

Email: sunny@szrfstar.com, sales@szrfstar.com

Web.: www.rfstariot.com, www.szrfstar.com

