



RF-BM-2340B1 And RF-BM-2340B1I CC2340R5
BLE 5.3 or ZigBee 3.0 Wireless Module Hardware
Specification
Version 1.1

Shenzhen RF-star Technology Co., Ltd.

Jun. 6th, 2024

All rights reserved. Those responsible for unauthorized reproduction will be prosecuted.

1 Device Overview

1.1 Description

RF-BM-2340B1 and RF-BM-2340B1I are RF modules based on TI lower-power CC2340R5 SoC. They are multiprotocol 2.4 GHz wireless modules supporting Thread, ZigBee®, Bluetooth® 5.3 Low Energy, IEEE 802.15.4, and proprietary 2.4 GHz. The modules integrate a 48 MHz crystal, 512 kB of in-system Programmable Flash, 12 kB ROM for bootloader, and 64 kB of ultra-low leakage SRAM. The ARM® Cortex®-M0+ core application processor can operate at an extremely low current at flexible power modes. And the modules enable long-range and low-power applications using 8 dBm high-power with best-in-class transmit current consumption at 12 mA. They feature a small size, robust connection distance, and rigid reliability. The 1.27-mm half-hole pitch stamp stick makes the module more convenient for application and development. RF-BM-2340B1 has a high-performance PCB antenna, while RF-BM-2340B1I has an IPEX connector or a half-hole RF out interface option for the different needs of external antennas. The UART serial port protocol can also enable you to start your development with a quick path.

1.2 Key Features

- RF Features
 - Bluetooth® 5.3 Low Energy
 - Bluetooth Mesh (Low power node)
 - ZigBee®
 - Thread
 - Proprietary
- TX power: up to +8 dBm with temperature compensation
- Excellent receiver sensitivity
 - -102 dBm for Bluetooth 125 kbps (LE coded PHY)
 - -99 dBm for Bluetooth 500 kbps (LE coded PHY)
 - -96.5 dBm for Bluetooth 1 Mbps
 - -92 dBm for Bluetooth 2 Mbps
- Wide Operation Range
 - Power supply:
 - ✧ GLDO mode: 1.71 V ~ 3.8 V, recommend to 3.3 V
 - ✧ DCDC mode: 2.2 V ~ 3.8 V, recommend to 3.3 V
 - Operating temperature: -40 °C to +85 °C
 - Storage temperature: -40 °C to +125 °C
 - Frequency range: 2360 MHz ~ 2510 MHz
- Microcontroller
 - Powerful 48 MHz ARM® Cortex®-M0+ processor
 - Integrated Balun
 - Support OTA upgrade
- Memory
 - 512 kB of in-system programmable flash
 - 12 kB of ROM for bootloader and drivers
 - 64 kB of ultra-low leakage SRAM. Retained in standby mode
- Rich Peripherals
 - 24 IO Pads
 - ✧ 2 IO pads SWD, muxed with GPIOs
 - ✧ Up to 22 DIOs (analog or digital IOs)
 - 3 × 16-bit or 1 × 24-bit general-purpose timers, Quadrature decode mode support
 - 12-bit ADC, 1.2 Msps with external reference, 267 kbps with internal reference, up to 12 external ADC inputs
 - 1 × low power comparator
 - 1 × UART
 - 1 × SPI
 - 1 × I²C

- Real-time clock (RTC)
- Integrated temperature and battery monitor
- Watchdog timer
- Security Enablers
 - AES 128-bit Crypto accelerator
 - Random number generator from on-chip analog noise
- Dimension:
 - RF-BM-2340B1: 22.50 mm × 15.55 mm × 2.10 mm
 - RF-BM-2340B1I: 22.50 mm × 15.55 mm × 2.10 mm
- RF-BM-2340B1 Certificates: BQB, SRRC, FCC, IC, CE, RoHS, Reach, TSCA

1.3 Applications

- Home healthcare
- Blood glucose monitors
- Blood pressure monitor
- CPAP machine
- Electronic thermometer
- Patient monitoring & diagnostics
- Medical sensor patches
- Personal care & Fitness
- Electric toothbrush
- Wearable fitness & activity monitor
- Building automation
- Building security systems
- Motion detector
- Electronic smart lock
- Door and window sensor
- Garage door system
- Gateway
- HVAC
- Thermostat
- Wireless environmental sensor
- Fire safety system
- Smoke and heat detector
- Video surveillance
- IP network camera
- Lighting
- LED luminaire
- Lighting Control
- Daylight sensor, lighting sensor
- Wireless control
- Factory automation and control
- Retail automation & payment
- Electronic point of sale
- Communication equipment
- Wired networking
- Personal electronics
- Connected peripherals
- Consumer wireless module
- Pointing devices
- Keyboards and keypads
- Gaming
- Electronic and robotic toys
- Wearables (non-medical)
- Smart trackers
- Smart clothing

1.4 Functional Block Diagram

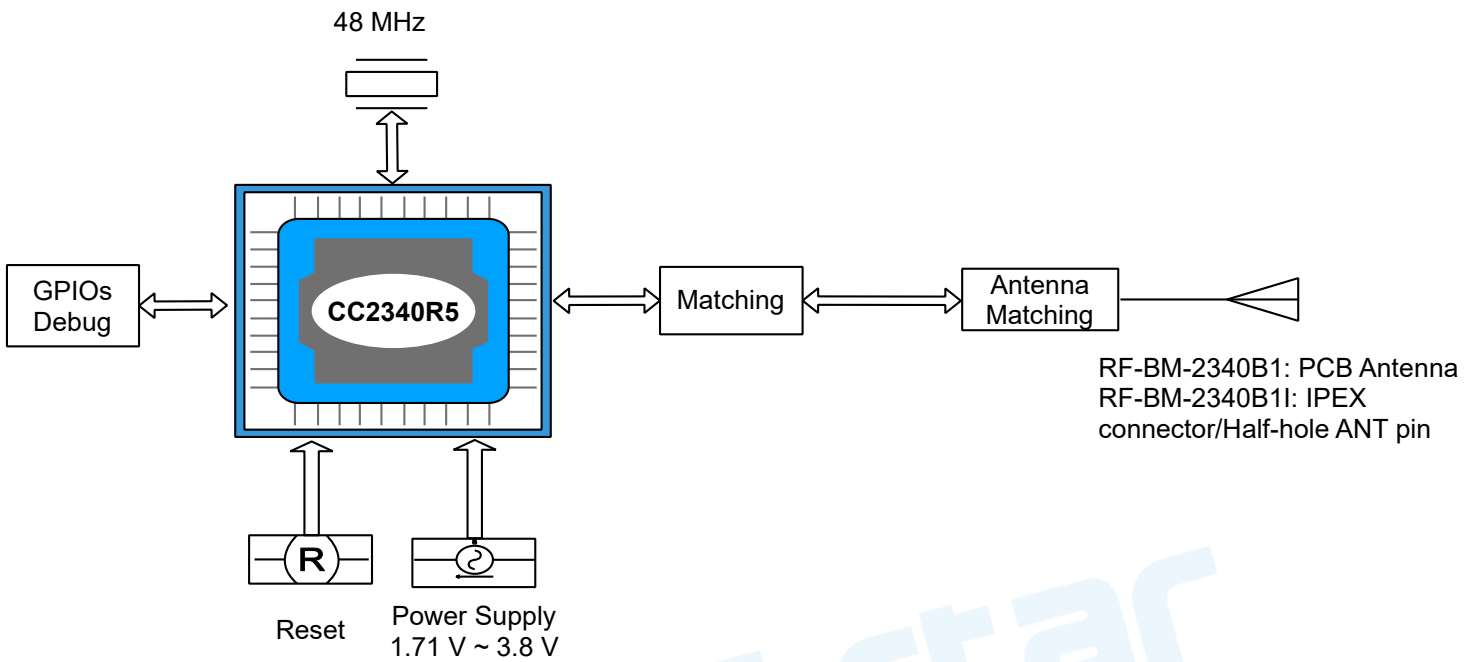

Figure 1. Functional Block Diagram of RF-BM-2340B1(I)

1.6 Part Number Conventions

The part numbers are of the form of RF-BM-2340B1(I) where the fields are defined as follows:

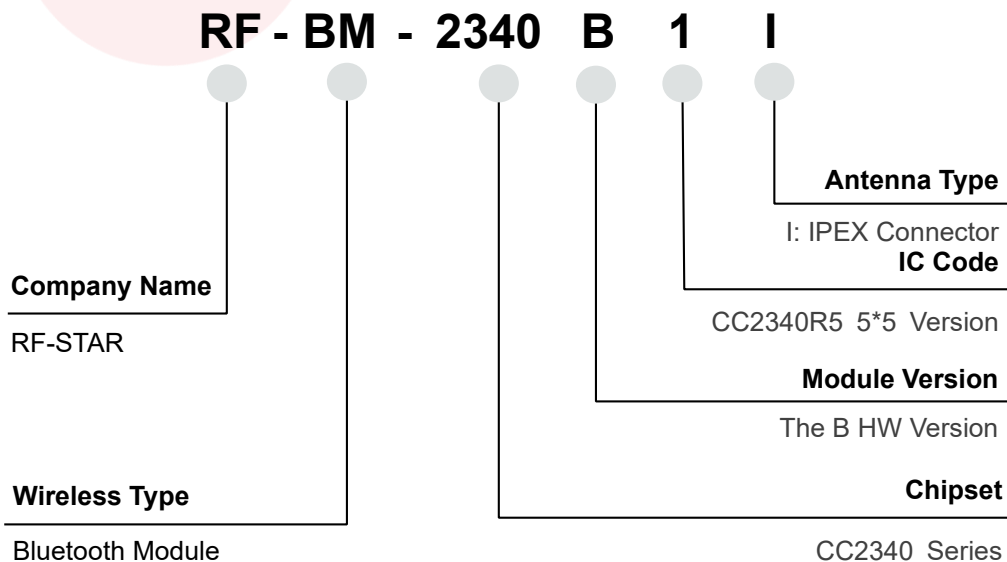

Figure 2. Part Number Conventions of RF-BM-2340B1(I)

Table of Contents

1 Device Overview	2
1.1 Description.....	2
1.2 Key Features	2
1.3 Applications.....	3
1.4 Functional Block Diagram	4
1.6 Part Number Conventions	4
Table of Contents.....	5
2 Module Configuration and Functions	7
2.1 Module Parameters.....	7
2.2 Module Pin Diagram	8
2.3 Pin Functions.....	8
2.4 Pin Peripheral Singal Descriptions.....	10
3 Specifications	13
3.1 Recommended Operating Conditions	13
3.2 Handling Ratings.....	13
4 Internal 32.768 kHz Crystal Setting	14
5 Application, Implementation, and Layout.....	15
5.1 Module Photos	15
5.2 Recommended PCB Footprint.....	15
5.3 Schematic Diagram.....	16
5.4 Reference Design	17
5.5 Antenna.....	18
5.5.1 Antenna Design Recommendation	18
5.5.2 Antenna Output Mode Modification.....	19
5.5.3 External Antenna Design Recommendation of the Half-Hole ANT Pin.....	19
5.5.4 IPEX Connector Specification	21
5.6 Basic Operation of Hardware Design	21
5.7 Trouble Shooting	22
5.7.1 Unsatisfactory Transmission Distance.....	22
5.7.2 Vulnerable Module.....	23
5.7.3 High Bit Error Rate	23
5.8 Electrostatics Discharge Warnings	23

5.9 Soldering and Reflow Condition.....	23
6 Optional Package Specification	25
7 Certificate.....	27
7.1 FCC.....	27
7.2 CE.....	27
7.3 IC.....	28
7.4 Reach.....	28
7.5 RoHS.....	29
7.6 SRRC.....	29
7.7 TSCA.....	30
7.8 BQB.....	30
8 Revision History	31
9 Contact Us.....	32



RF-star

2 Module Configuration and Functions

2.1 Module Parameters

Table 1. Parameters of RF-BM-2340B1(I)

Chipset	CC2340R5
Supply Power Voltage	DCDC mode: 2.2 V ~ 3.8 V, 3.3 V is recommended GLDO mode: 1.71 V ~ 3.8 V, 3.3 V is recommended Remark: When set to DCDC mode, if the supply voltage is lower than 2.2 V, it will automatically switch to GLDO mode.
Frequency	2360 MHz ~ 2510 MHz
Maximum Transmit Power	+8.0 dBm
Receiving Sensitivity	-102 dBm @ Bluetooth 125 kbps (LE Coded PHY) -99 dBm @ Bluetooth 500 kbps (LE Coded PHY) -96.5 dBm @ Bluetooth 1 Mbps -92 dBm @ Bluetooth 2 Mbps
GPIO	24
Flash	512 kB
ROM	12 kB for bootloader and drivers
SRAM	64 kB
Power Consumption	RX current: 5.3 mA TX current: 5.1 mA @ 0 dBm < 11.0 mA @ 8 dBm MCU (CoreMark): 2.6 mA @ active mode Standby: < 710 nA @RTC, 36 kB RAM Shutdown: 150 nA @ wake-up on pin
Support Protocol	Bluetooth 5.3 Low Energy, ZigBee, Proprietary, SimpleLink TI 15.4-stack
Crystal	48 MHz, 32.768 kHz
Package	SMT packaging (1.27-mm half-hole pitch stamp stick)
Dimension	22.50 mm × 15.55 mm × 2.1 mm
Type of Antenna	RF-BM-2340B1: PCB antenna RF-BM-2340B1I: IPEX connector or RF ANT pin
Operating Temperature	-40 °C ~ +85 °C
Storage Temperature	-40 °C ~ +125 °C

2.2 Module Pin Diagram

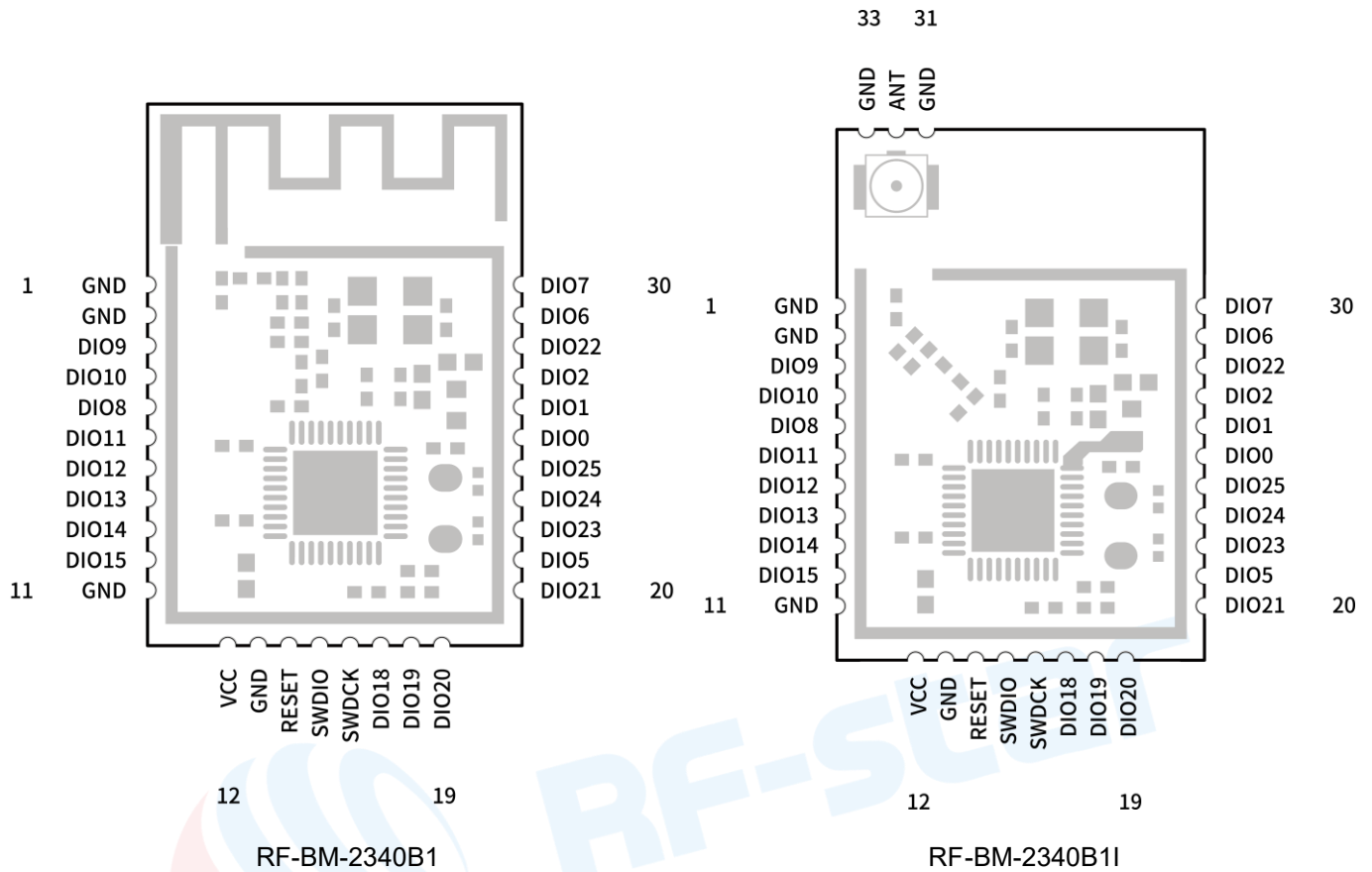

Figure 3. Pin Diagram of RF-BM-2340B1(I)

2.3 Pin Functions

Table 2. Pin Functions of RF-BM-2340B1(I)

Pin	Name	Chip Pin	Function	Description
1	GND	GND	Ground	Ground
2	GND	GND	Ground	Ground
3	DIO9	DIO9	Digital	GPIO
4	DIO10	DIO10	Digital	GPIO
5	DIO8	DIO8	Digital	GPIO
6	DIO11	DIO11	Digital	GPIO
7	DIO12	DIO12	Digital	GPIO, high-drive capability
8	DIO13	DIO13	Digital	GPIO
9	DIO14	DIO14	Digital	GPIO
10	DIO15	DIO15	Digital	GPIO
11	GND	GND	Ground	Ground

12	VCC	VCCS	VCC	Power supply: 1.71 V ~ 3.8 V, recommended to 3.3 V
13	GND	GND	GND	Ground
14	RESET	RSTN	Digital	Reset, active low. Internal pullup.
15	SWDIO ¹	DIO16_SWDIO	Digital	GPIO, SWD interface: mode select or SWDIO (JTAG_TMSC), high-drive capability, No floating
16	SWDCK ¹	DIO17_SWDCK	Digital	GPIO, SWD interface: clock(JTAG_TCKC), high-drive capability, No floating
17	DIO18	DIO18	Digital	GPIO, high-drive capability
18	DIO19	DIO19	Digital	GPIO, high-drive capability
19	DIO20	DIO20_A11	Digital or Analog	GPIO, analog capability
20	DIO21	DIO21_A10	Digital or Analog	GPIO, analog capability
21	DIO5	DIO5_A2	Digital or Analog	GPIO, analog capability
22	DIO23	DIO23_A8	Digital or Analog	GPIO, analog capability
23	DIO24	DIO24_A7	Digital or Analog	GPIO, analog capability, high-drive capability
24	DIO25	DIO25_A6	Digital or Analog	GPIO, analog capability
25	DIO0	DIO0_A5	Digital or Analog	GPIO, analog capability
26	DIO1	DIO1_A4	Digital or Analog	GPIO, analog capability
27	DIO2	DIO2_A3	Digital or Analog	GPIO, analog capability
28	DIO22	DIO22_A9	Digital or Analog	GPIO, analog capability
29	DIO6	DIO6_A1	Digital or Analog	GPIO, analog capability
30	DIO7	DIO7_A0	Digital or Analog	GPIO, analog capability
31	GND	GND	Ground	Ground, for RF-BM-2340B1I only
32	ANT	ANT	RF	External ANT output pin, for RF-BM-2340B1I only
33	GND	GND	Ground	Ground, for RF-BM-2340B1I only

Remark 1: Floating is prohibited. SWDIO and SWDCK need to be internally or externally pulled up/down (our module does not have external pull-up/down resistors). Otherwise, leakage current may be caused, resulting in excessive power consumption.

2.4 Pin Peripheral Singal Descriptions

Table 3. Pin Peripheral Singal Description of RF-BM-2340B1(I)

Function	Singal Name	Module Pin	Chip Pin	Signal Direction	Description
UART	UART0TXD	DIO13	DIO13	O	UART0 TX data
		DIO17	DIO17_SWDCK		
		DIO18	DIO18		
		DIO20	DIO20_A11		
		DIO6	DIO6_A1		
	UART0RXD	DIO12	DIO12	I	UART0 RX data
		DIO15	DIO15		
		DIO16	DIO16_SWDIO		
		DIO20	DIO20_A11		
		DIO22	DIO22_A9		
	UART0CTS	DIO21	DIO21_A10	I	UART0 clear-to-send input (active low)
		DIO2	DIO2_A3		
	UART0RTS	DIO8	DIO8	O	UART0 request-to-send (active low)
		DIO1	DIO1_A4		
ADC	ADC11	DIO20	DIO20_A11	I	HP ADC channel 11 input
	ADC10/LPC+	DIO21	DIO21_A10		HP ADC channel 10 input
	ADC9	DIO22	DIO22_A9		HP ADC channel 9 input
	ADC8/LPC+/LPC-	DIO23	DIO23_A8		HP ADC channel 8 input
	ADC7/LPC+/LPC-	DIO24	DIO24_A7		HP ADC channel 7 input
	ADC6	DIO25	DIO25_A6		ADC channel 6 input
	ADC5	DIO0	DIO0_A5		ADC channel 5 input
	ADC4	DIO1	DIO1_A4		ADC channel 4 input
	ADC3	DIO2	DIO2_A3		ADC channel 3 input
	ADC2	DIO5	DIO5_A2		ADC channel 2 input
	ADC1	DIO6	DIO6_A1		HP ADC channel 1 input.
ADC0	DIO7	DIO7_A0	HP ADC channel 0 input.		
ADC	AREF+	DIO6	DIO6_A1	I	ADC external voltage reference, positive terminal

Reference	AREF-	DIO7	DIO7_A0		ADC external voltage reference, negative terminal
------------------	-------	------	---------	--	---

Table 4. Pin Peripheral Singal Description of RF-BM-2340B1(I) (Continued 1)

Function	Singal Name	Module Pin	Chip Pin	Signal Direction	Description	
SPI	SPI0SCLK	DIO8	DIO8	I/O	SPI clock	
		DIO17	DIO17_SWDCCK			
		DIO18	DIO18			
		DIO24	DIO24_A7			
	SPI0POCI		DIO11	DIO11	I/O	SPI POCI (MISO)
			DIO12	DIO12		
			DIO13	DIO13		
			DIO20	DIO20_A11		
			DIO25	DIO25_A6		
	SPI0CSN		DIO11	DIO11	I/O	SPI chip select
			DIO0	DIO0_A5		
			DIO6	DIO6_A1		
	SPI0PICO		DIO12	DIO12	I/O	SPI PICO (MOSI)
			DIO13	DIO13		
DIO16			DIO16_SWDDIO			
DIO19			DIO19			
I ² C	I2C0SCL	DIO17	DIO17_SWDCCK	I/O	I2C clock data	
		DIO24	DIO24_A7			
		DIO25	DIO25_A6			
		DIO6	DIO6_A1			
	I2C0SDA		DIO8	DIO8	I/O	I2C data
			DIO12	DIO12		
			DIO16	DIO16_SWDDIO		
			DIO0	DIO0_A5		

Table 5. Pin Peripheral Singal Description of RF-BM-2340B1(I) (Continued 2)

Function	Singal Name	Module Pin	Chip Pin	Signal Direction	Description
GPIO	GPIO8	DIO8	DIO8	I/O	General-purpose input or output
	GPIO9	DIO9	DIO9		
	GPIO10	DIO10	DIO10		
	GPIO11	DIO11	DIO11		
	GPIO12	DIO12	DIO12		
	GPIO13	DIO13	DIO13		
	GPIO14	DIO14	DIO14		
	GPIO15	DIO15	DIO15		
	GPIO16	DIO16	DIO16_SWDIO		
	GPIO17	DIO17	DIO17_SWDCK		
	GPIO18	DIO18	DIO18		
	GPIO19	DIO19	DIO19		
	GPIO20	DIO20	DIO20_A11		
	GPIO21	DIO21	DIO21_A10		
	GPIO22	DIO22	DIO22_A9		
	GPIO23	DIO23	DIO23_A8		
	GPIO24	DIO24	DIO24_A7		
	GPIO25	DIO25	DIO25_A6		
	GPIO0	DIO0	DIO0_A5		
	GPIO1	DIO1	DIO1_A4		
	GPIO2	DIO2	DIO2_A3		
	GPIO5	DIO5	DIO5_A2		
	GPIO6	DIO6	DIO6_A1		
	GPIO7	DIO7	DIO7_A0		

3 Specifications

3.1 Recommended Operating Conditions

The functional operation does not guarantee performance beyond the limits of the conditional parameter values in the table below. Long-term work beyond this limit will affect the reliability of the module more or less.

Table 6. Recommended Operating Conditions of RF-BM-2340B1(I)

Items	Condition	Min.	Typ.	Max.	Unit
Operating Supply Voltage	/	1.71	3.3	3.8	V
Operating Temperature	/	-40	+25	+85	°C

3.2 Handling Ratings

Table 7. Handling Ratings of RF-BM-2340B1(I)

Items	Condition	Min.	Typ.	Max.	Unit
Storage Temperature	Tstg	-40	+25	+125	°C
Human Body Model	HBM		±1000		V
Moisture Sensitivity Level			3		
Charged Device Model			±500		V

4 Internal 32.768 kHz Crystal Setting

The module hardware is without an external 32.768 kHz crystal by default. However, the SDK adopts the external 32.768 kHz crystal by default, pls see the details below:

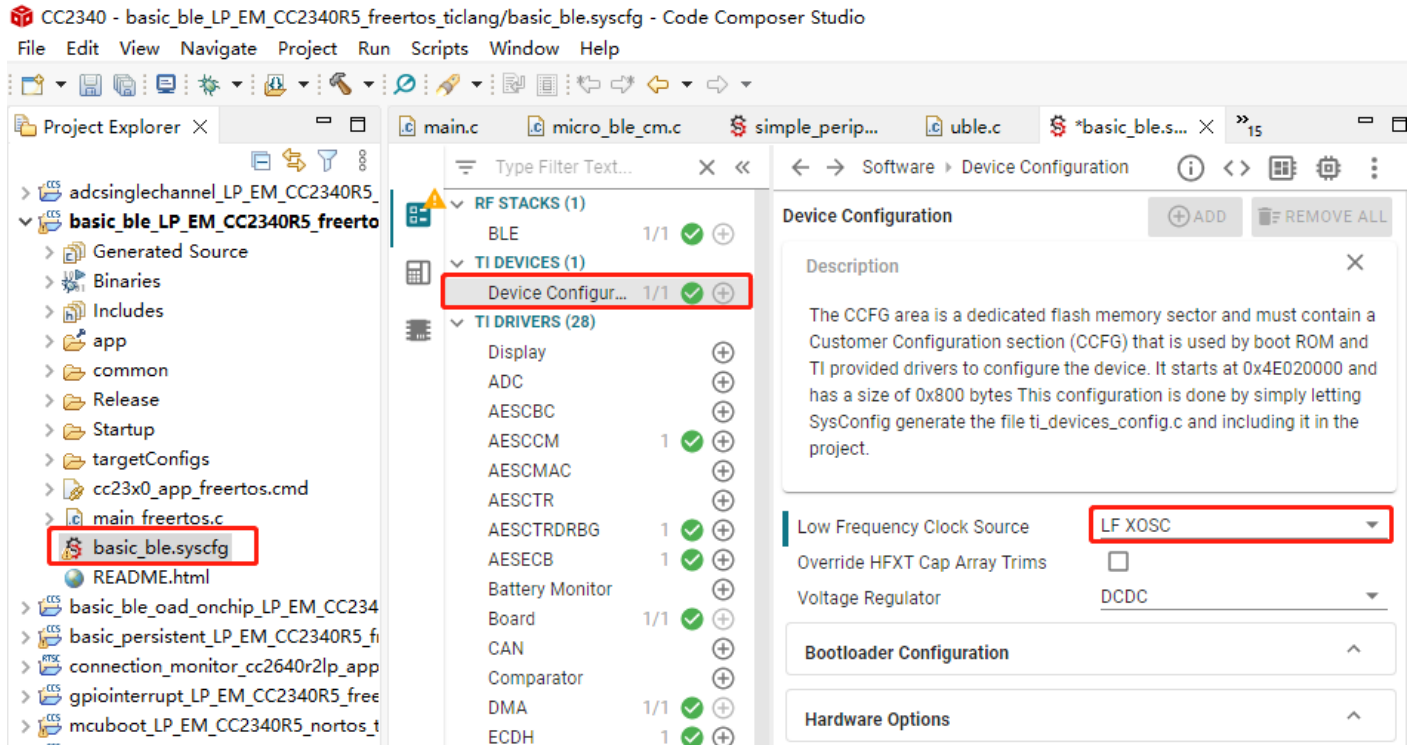

Therefore, in order no problem during debugging, pls modify the default crystal setting to the internal crystal LFRCOS as follows:

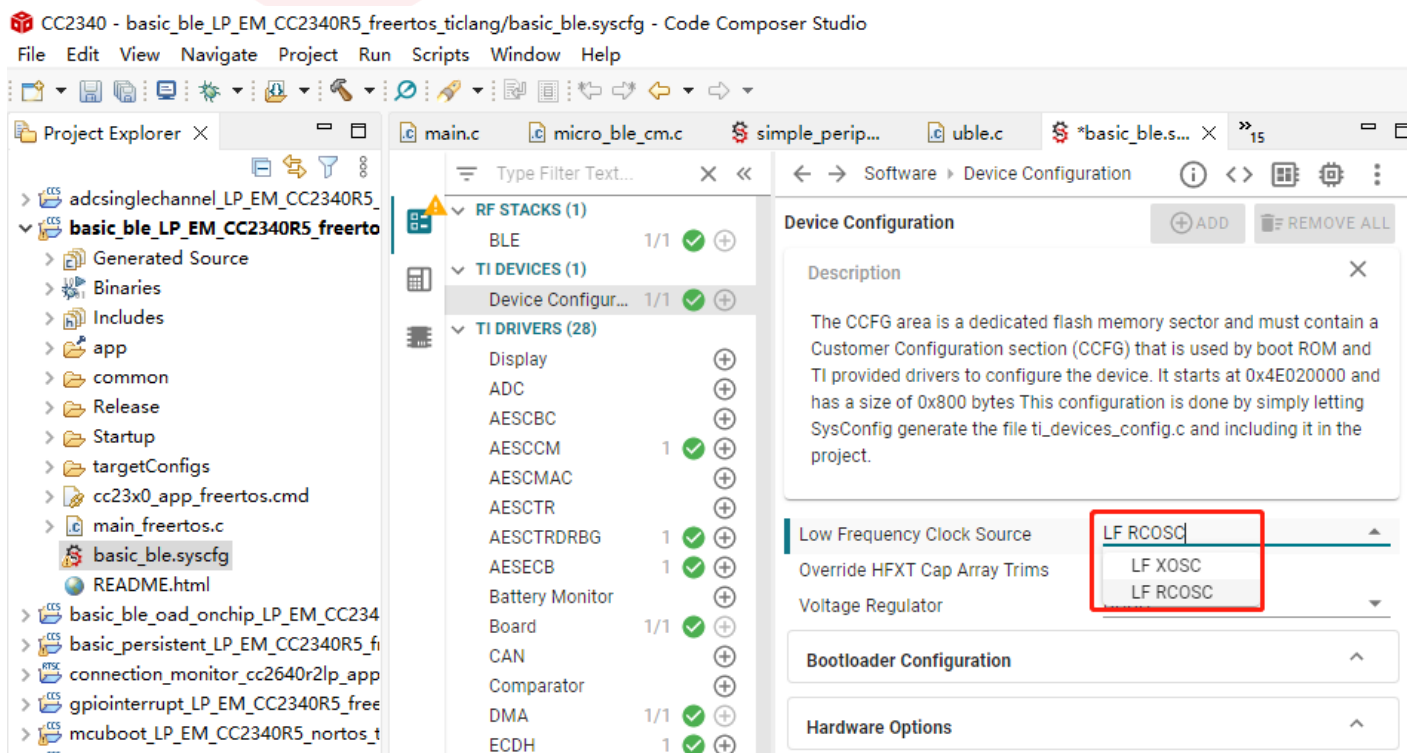

5 Application, Implementation, and Layout

5.1 Module Photos

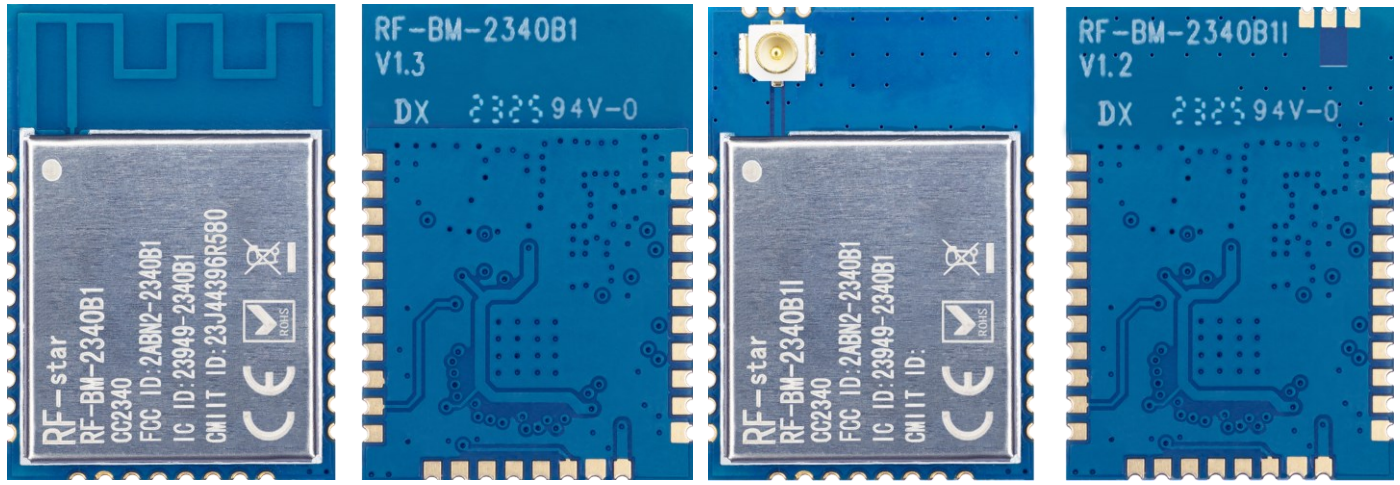

RF-BM-2340B1

RF-BM-2340B1I

Figure 3. Photos of RF-BM-2340B1(I)

5.2 Recommended PCB Footprint

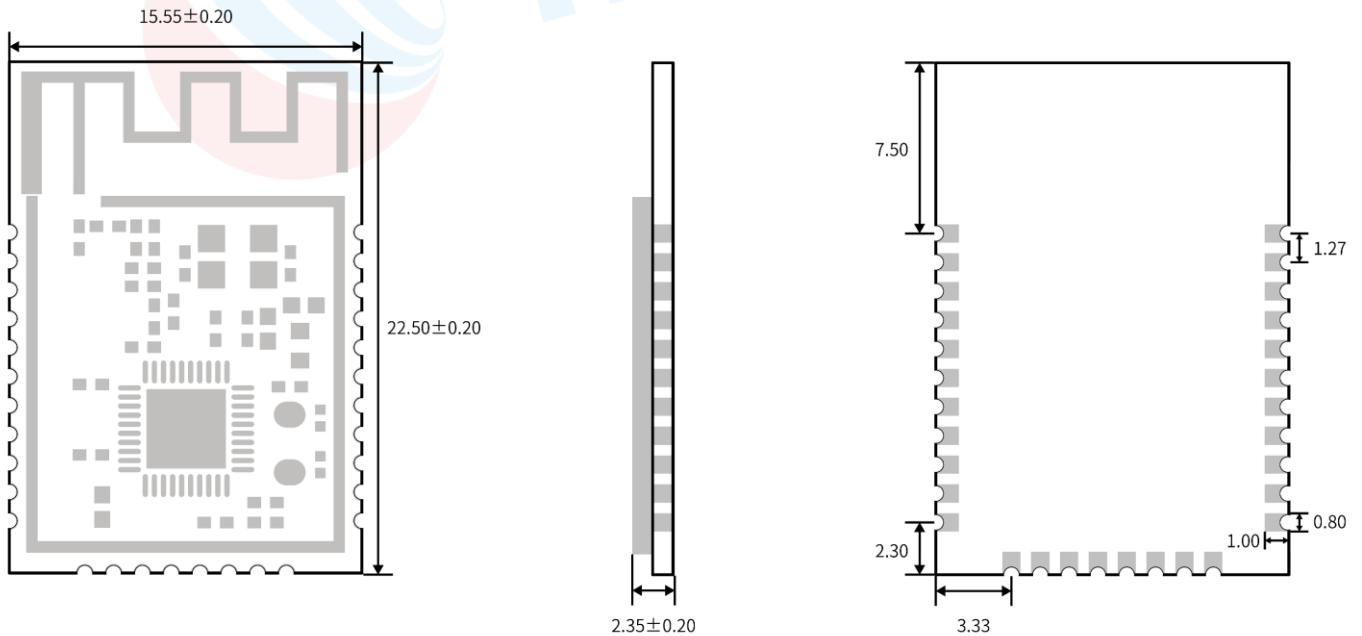

RF-BM-2340B1



RF-BM-2340B1I

Figure 4. Recommended PCB Footprint of RF-BM-2340B1(I)

5.3 Schematic Diagram

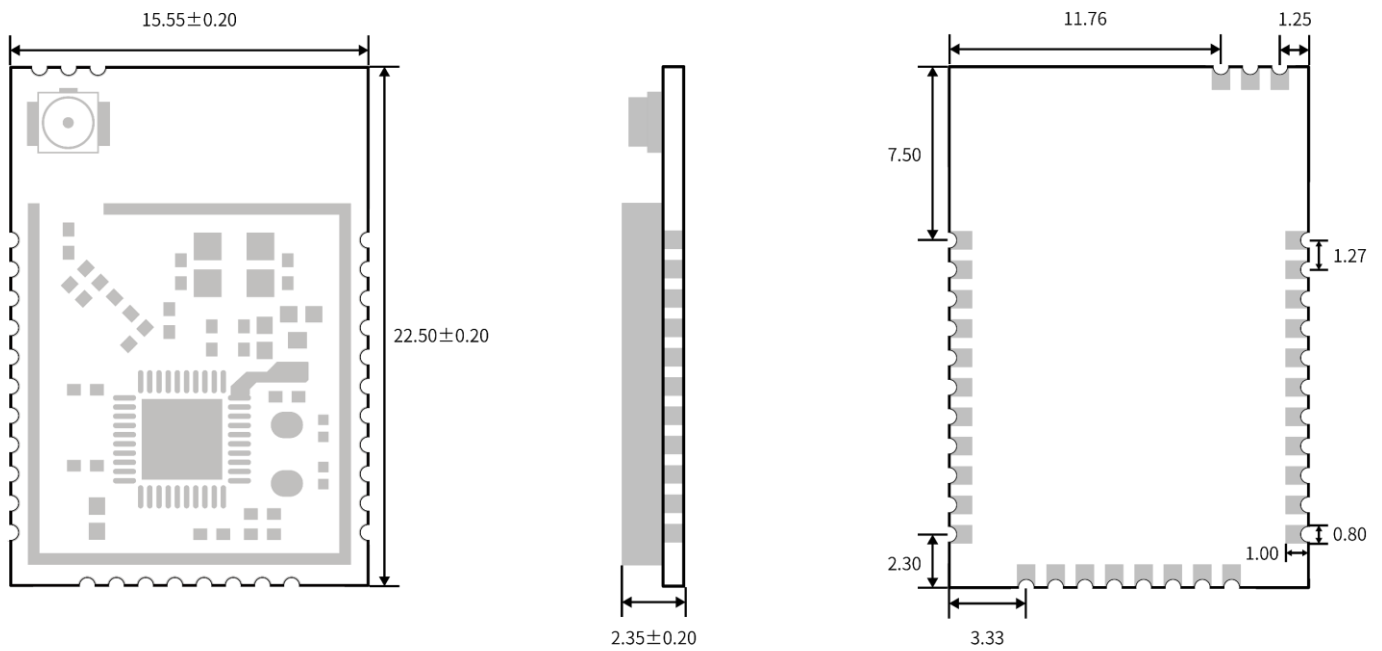
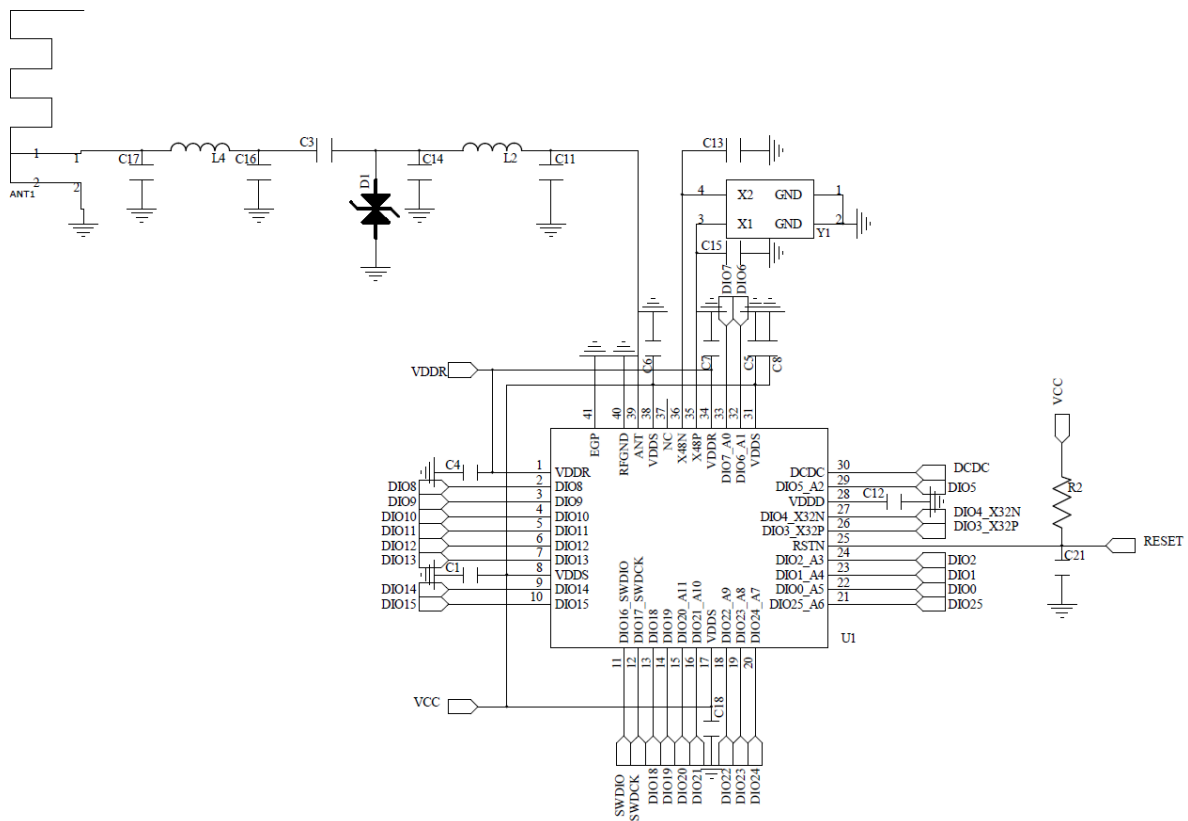
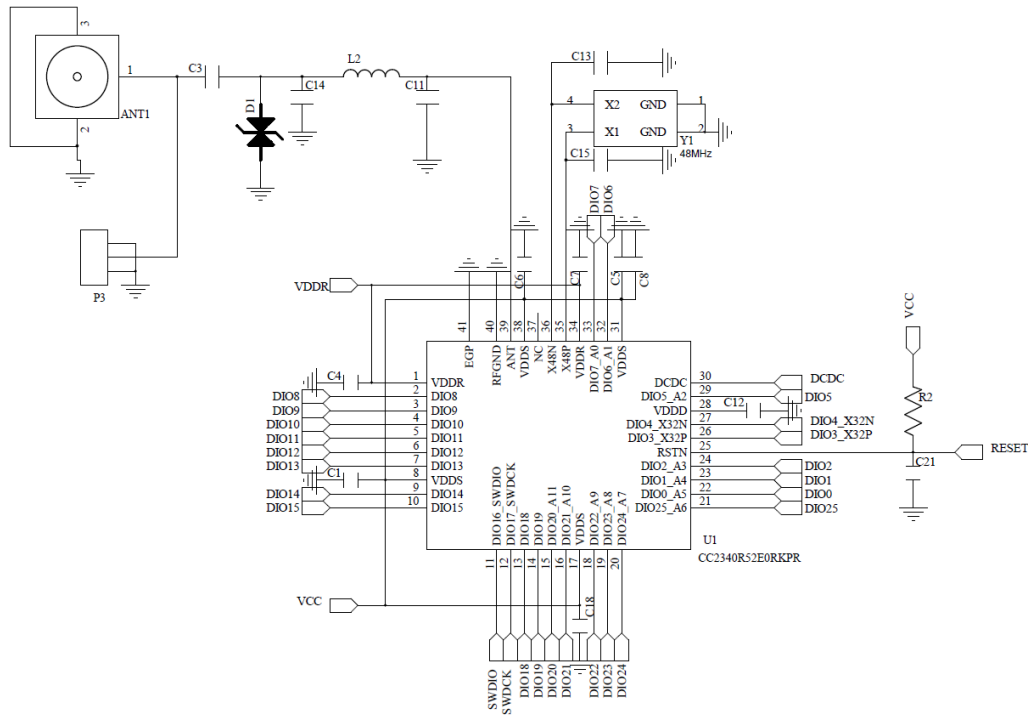

RF-BM-2340B1



RF-BM-2340B1I

Figure 5. Schematic Diagram of RF-BM-2340B1(I)

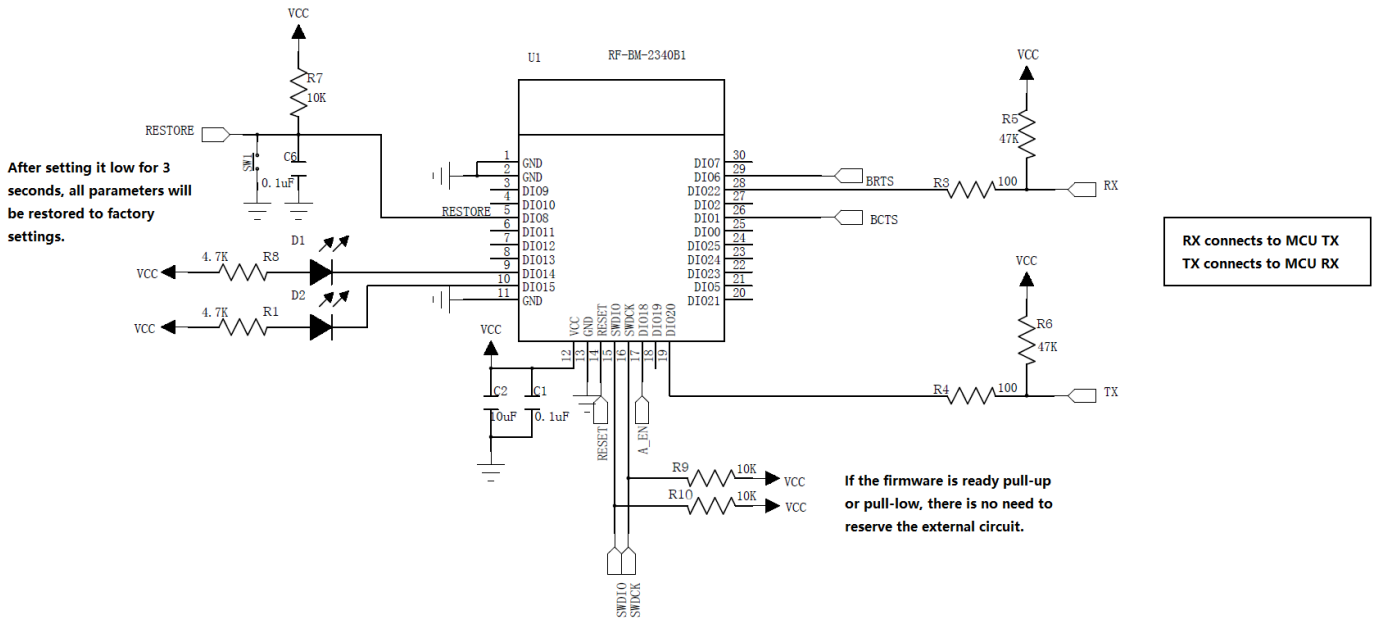
5.4 Reference Design



RF-BM-2340B1

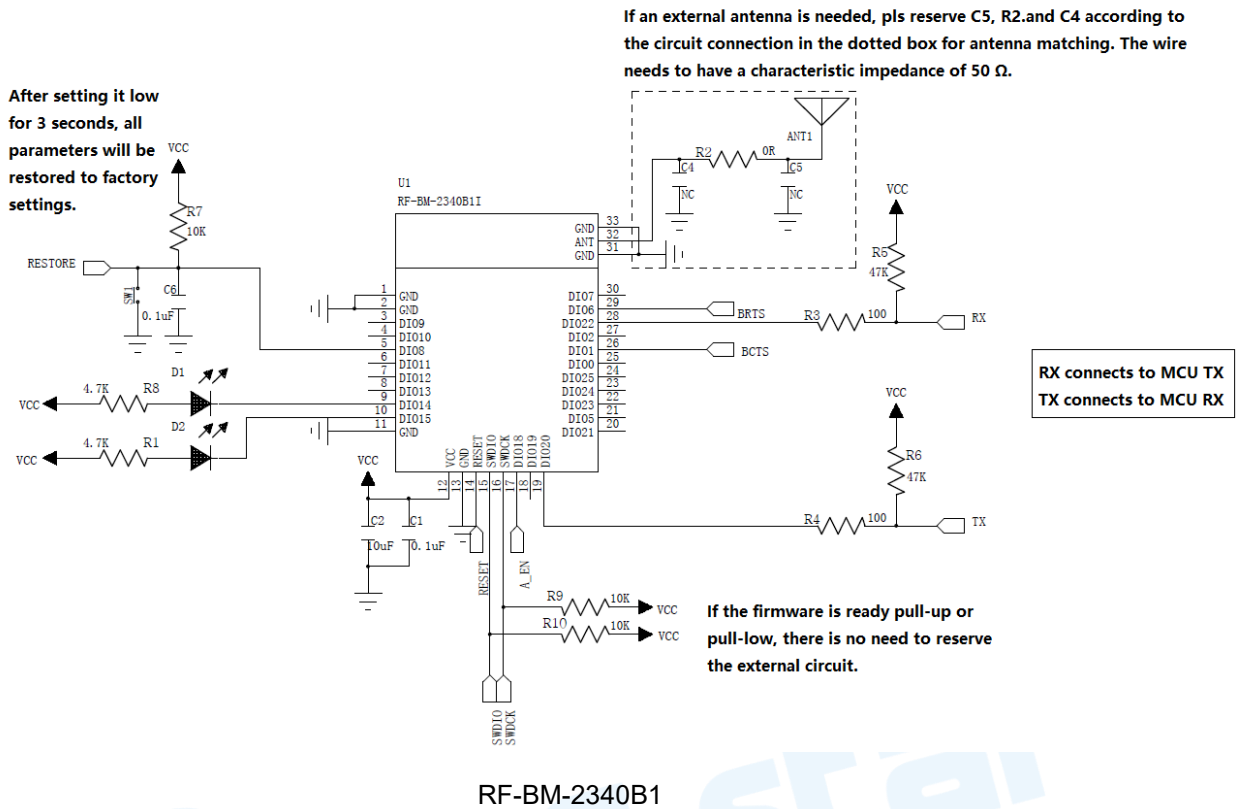

Figure 5. Reference Design of RF-BM-2340B1(I)

5.5 Antenna

5.5.1 Antenna Design Recommendation

1. The antenna installation structure has a great influence on the module performance. It is necessary to ensure the antenna is exposed and preferably vertically upward. When the module is installed inside of the case, a high-quality antenna extension wire can be used to extend the antenna to the outside of the case.
2. The antenna must not be installed inside the metal case, which will cause the transmission distance to be greatly weakened.
3. The recommendation of antenna layout.

The inverted-F antenna position on PCB is free-space electromagnetic radiation. The location and layout of the antenna are key factors to increase the data rate and transmission range.

Therefore, the layout of the module antenna location and routing is recommended as follows:

- (1) Place the antenna on the edge (corner) of the PCB.
- (2) Make sure that there is no signal line or copper foil in each layer below the antenna.
- (3) It is best to hollow out the antenna position in the following figure to ensure that the S11 of the module is minimally affected.

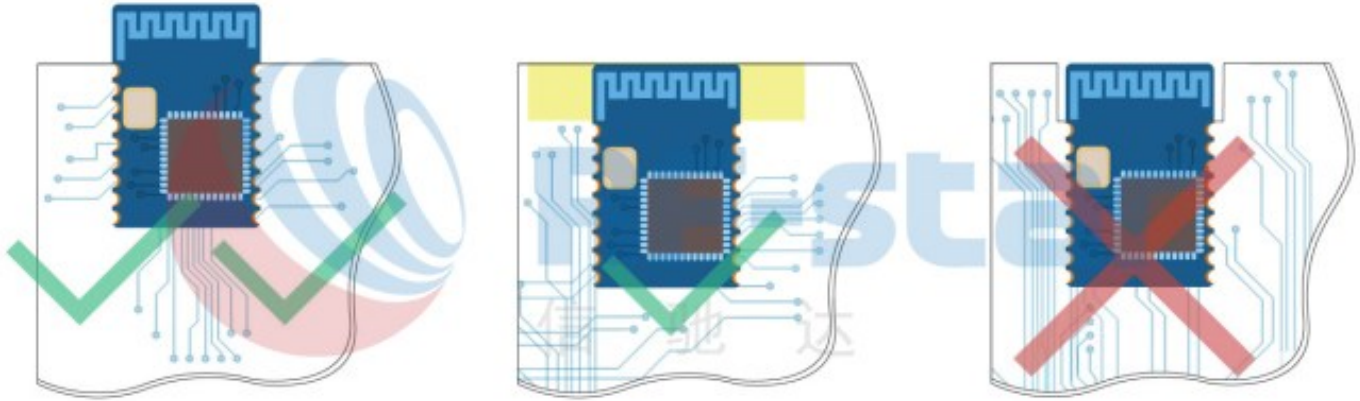

Figure 4. Recommendation of Antenna Layout

Note: The hollow-out position is based on the antenna used.

5.5.2 Antenna Output Mode Modification

RF-BM-2340B1I has two antenna output modes. One is an IPEX connector and the other is a stamp half-hole output (ANT pin, see pin function table for details).

The default delivery is the **IPEX connector**, and the capacitor connected to the IPEX is welded. If you want to use the external antenna by the ANT pin, just connect the external antenna to the ANT pin. Pls kindly refer to the reference design as above.

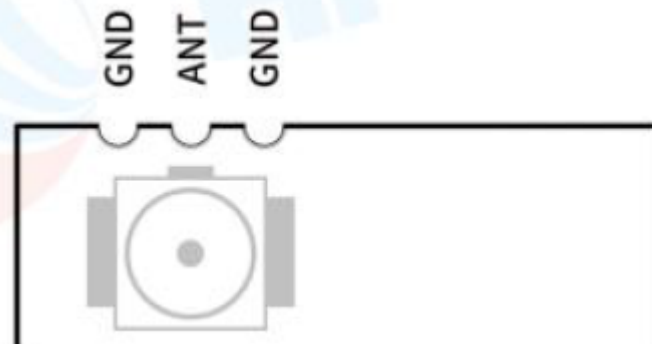

5.5.3 External Antenna Design Recommendation of the Half-Hole ANT Pin

1. A Π -type matching circuit is reserved for the antenna, and $50\ \Omega$ impedance control is performed on the RF traces. The traces are as short as possible, and 135° or arc traces are used as much as possible. No vias are used to change layers. More GND vias are placed around the RF traces.

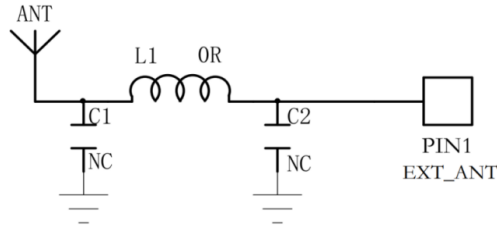

Figure 5. Reference Design of the External Antenna

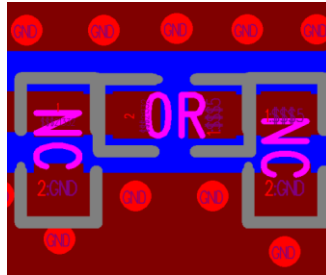

Figure 6. Reference Design of the External Antenna Traces

2. The RF trace width and copper-clad spacing can be calculated by SI9000 software, and the impedance is controlled to 50Ω according to the actual board thickness, number of layers, plate, dielectric thickness, dielectric constant, copper thickness, line width, line spacing, and solder mask thickness.

Example: FR4 is a double-layer board with a thickness of 1.0 mm. Through calculation, the width of the trace is 0.8254 mm, and the spacing between traces and copper is 0.22 mm.

Parameter Entry Units		Units				
		Mils	Inches	Microns	Millimetres	
Substrate 1 Height	H1	0.8800 +/-	0.0000	0.8800	0.8800	Calculate
Substrate 1 Dielectric	Er1	4.4000 +/-	0.0000	4.4000	4.4000	Calculate
Lower Trace Width	W1	0.8254 +/-	0.0000	0.8254	0.8254	Calculate
Upper Trace Width	W2	0.8000 +/-	0.0000	0.8000	0.8000	Calculate
Ground Strip Separation	D1	0.2200 +/-	0.0000	0.2200	0.2200	Calculate
Trace Thickness	T1	0.0350 +/-	0.0000	0.0350	0.0350	Calculate
Coating Above Substrate	C1	0.0254 +/-	0.0000	0.0254	0.0254	
Coating Above Trace	C2	0.0254 +/-	0.0000	0.0254	0.0254	
Coating Dielectric	CEr	4.2000 +/-	0.0000	4.2000	4.2000	
Impedance	Zo	50.10		50.10	50.10	Calculate

Notes: Add your comments here

Interface Style: Standard Extended

G.S. Convergence: Fine (Slower) Coarse (Faster)

Figure 7. SI9000 Impedance Calculation Diagram

5.5.4 IPEX Connector Specification

RF-BM-2340B1I module is integrated with the IPEX version 1 antenna seat, the specification of the antenna seat is as follows:

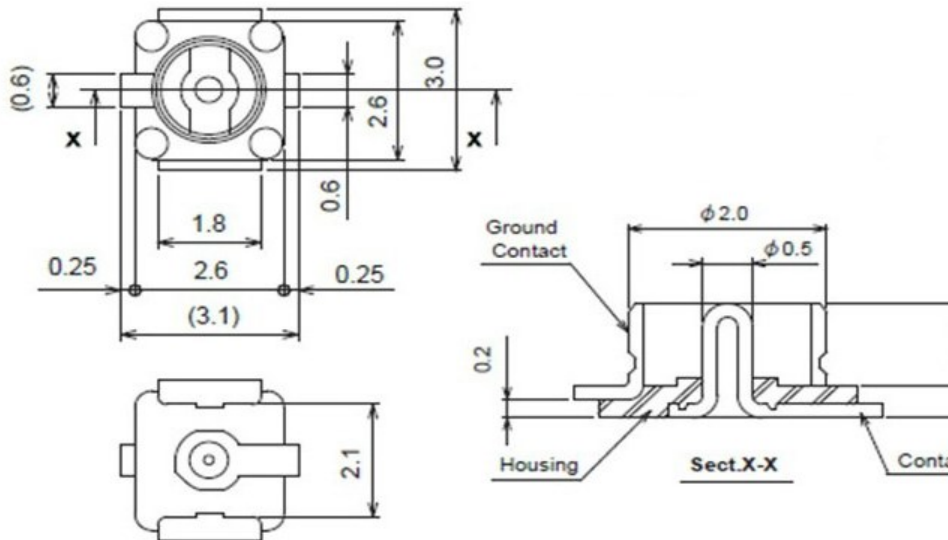

Figure 8. Specification of Antenna Seat

The specification of the IPEX wire end is as follows:

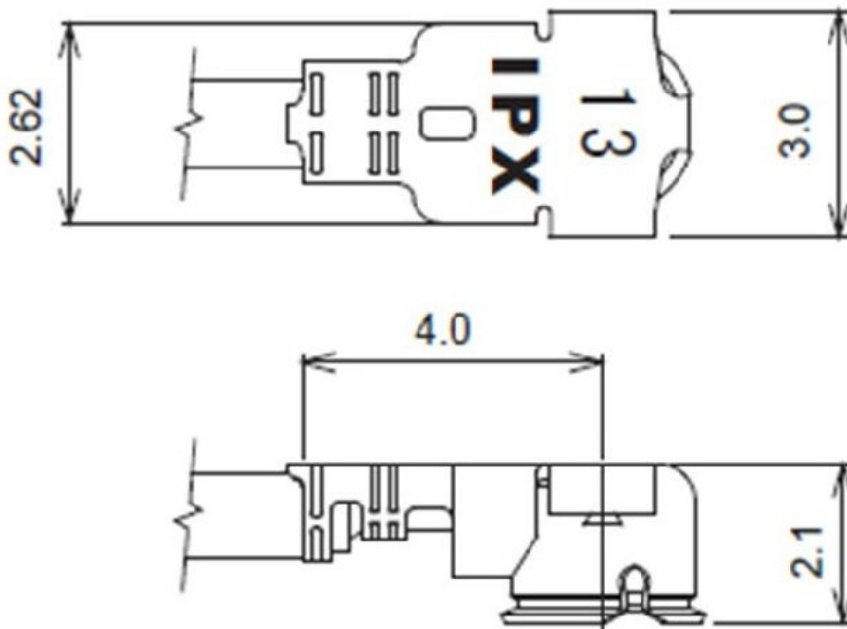

Figure 9. Specification of IPEX Wire

5.6 Basic Operation of Hardware Design

1. It is recommended to offer the module a DC stabilized power supply, a tiny power supply ripple coefficient, and reliable ground. Please pay attention to the correct connection between the positive and negative poles of the power

supply. Otherwise, the reverse connection may cause permanent damage to the module.

2. Please ensure the supply voltage is between the recommended values. The module will be permanently damaged if the voltage exceeds the maximum value. Please ensure a stable power supply and no frequently fluctuating voltage.
3. When designing the power supply circuit for the module, it is recommended to reserve more than 30% of the margin, which is beneficial to the long-term stable operation of the whole machine. The module should be far away from the power electromagnetic, transformer, high-frequency wiring, and other parts with large electromagnetic interference.
4. The bottom of the module should avoid high-frequency digital routing, high-frequency analog routing, and power routing. If it has to route the wire on the bottom of the module, for example, it is assumed that the module is soldered to the Top Layer, the copper must be spread on the connection part of the top layer and the module, and be close to the digital part of the module and routed in the Bottom Layer (all copper is well-grounded).
5. Assuming that the module is soldered or placed in the Top Layer, it is also wrong to randomly route the Bottom Layer or other layers, which will affect the spurs and receiving sensitivity of the module to some degree.
6. Assuming that there are devices with large electromagnetic interference around the module, which will greatly affect the module performance. It is recommended to stay away from the module according to the strength of the interference. If circumstances permit, appropriate isolation and shielding can be done.
7. Assuming that there are routings of large electromagnetic interference around the module (high-frequency digital, high-frequency analog, power routings), which will also greatly affect the module performance. It is recommended to stay away from the module according to the strength of the interference. If circumstances permit, appropriate isolation and shielding can be done.
8. It is recommended to stay away from the devices whose TTL protocol is the same 2.4 GHz physical layer, for example, USB 3.0.

5.7 Trouble Shooting

5.7.1 Unsatisfactory Transmission Distance

1. When there is a linear communication obstacle, the communication distance will be correspondingly weakened. Temperature, humidity, and co-channel interference will lead to an increase in the communication packet loss rate. The performances of ground absorption and reflection of radio waves will be poor when the module is tested close to the ground.
2. Seawater has a strong ability to absorb radio waves, so the test results by the seaside are poor.
3. The signal attenuation will be very obvious if there is metal near the antenna or if the module is placed inside the metal shell.
4. The incorrect power register set or the high data rate in the open air may shorten the communication distance. The higher the data rate, the closer the distance.

5. The low voltage of the power supply is lower than the recommended value at ambient temperature, and the lower the voltage, the smaller the power is.
6. The unmatchable antennas and modules or the poor quality of antenna will affect the communication distance.

5.7.2 Vulnerable Module

1. Please ensure the supply voltage is between the recommended values. The module will be permanently damaged if the voltage exceeds the maximum value. Please ensure a stable power supply and no frequently fluctuating voltage.
2. Please ensure the anti-static installation and the electrostatic sensitivity of high-frequency devices.
3. Due to some humidity-sensitive components, please ensure the suitable humidity during installation and application. If there is no special demand, it is not recommended to use at too high or too low temperature.

5.7.3 High Bit Error Rate

1. There are co-channel signal interferences nearby. It is recommended to be away from the interference sources or modify the frequency and channel to avoid interferences.
2. The unsatisfactory power supply may also cause garbled. It is necessary to ensure the power supply's reliability.
3. If the extension wire or feeder wire is of poor quality or too long, the bit error rate will be high.

5.8 Electrostatics Discharge Warnings

The module will be damaged by the discharge of static. RF-star suggests that all modules should follow the 3 precautions below:

1. According to the anti-static measures, bare hands are not allowed to touch modules.
2. Modules must be placed in anti-static areas.
3. Take the anti-static circuitry (when inputting HV or VHF) into consideration in product design.
Static may result in the degradation in performance of the module, even causing failure.

5.9 Soldering and Reflow Condition

1. Heating method: Conventional Convection or IR/convection.
2. Solder paste composition: Sn96.5/Ag3.0/Cu0.5
3. Allowable reflow soldering times: 2 times based on the following reflow soldering profile.
4. Temperature profile: Reflow soldering shall be done according to the following temperature profile.
5. Peak temperature: 245 °C.

Table 8. Temperature Table of Soldering and Reflow

Profile Feature	Sn-Pb Assembly	Pb-Free Assembly
-----------------	----------------	------------------

Solder Paste	Sn63 / Pb37	Sn96.5 / Ag3.0 / Cu0.5
Min. Preheating Temperature (T_{min})	100 °C	150 °C
Max. Preheating Temperature (T_{max})	150 °C	200 °C
Preheating Time (T_{min} to T_{max}) (t_1)	60 s ~ 120 s	60 s ~ 120 s
Average Ascend Rate (T_{max} to T_p)	Max. 3 °C/s	Max. 3 °C/s
Liquid Temperature (T_L)	183 °C	217 °C
Time above Liquidus (t_L)	60 s ~ 90 s	30 s ~ 90 s
Peak Temperature (T_p)	220 °C ~ 235 °C	230 °C ~ 250 °C
Average Descend Rate (T_p to T_{max})	Max. 6 °C/s	Max. 6 °C/s
Time from 25 °C to Peak Temperature (t_2)	Max. 6 minutes	Max. 8 minutes
Time of Soldering Zone (t_p)	20±10 s	20±10 s

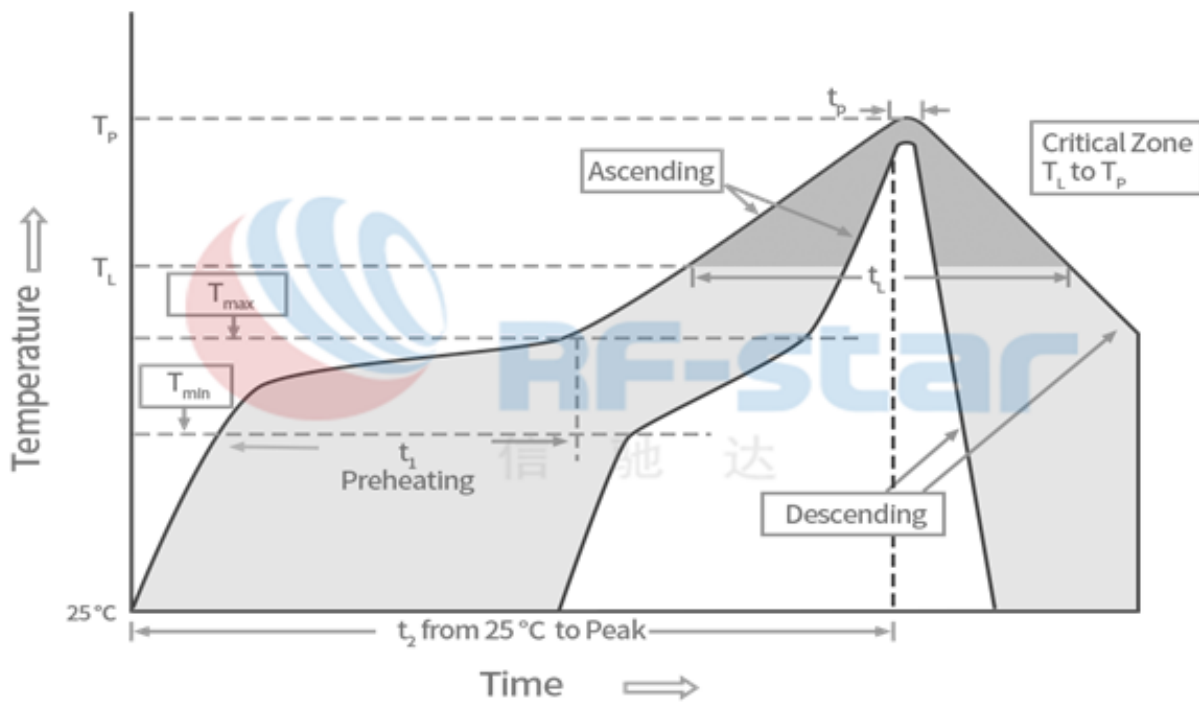

Figure 10. Recommended Reflow for Lead-Free Solder

6 Optional Package Specification

The default package method is **by tray**. If you need the modules to be shipped by tape & reel, pls contact us in advance.

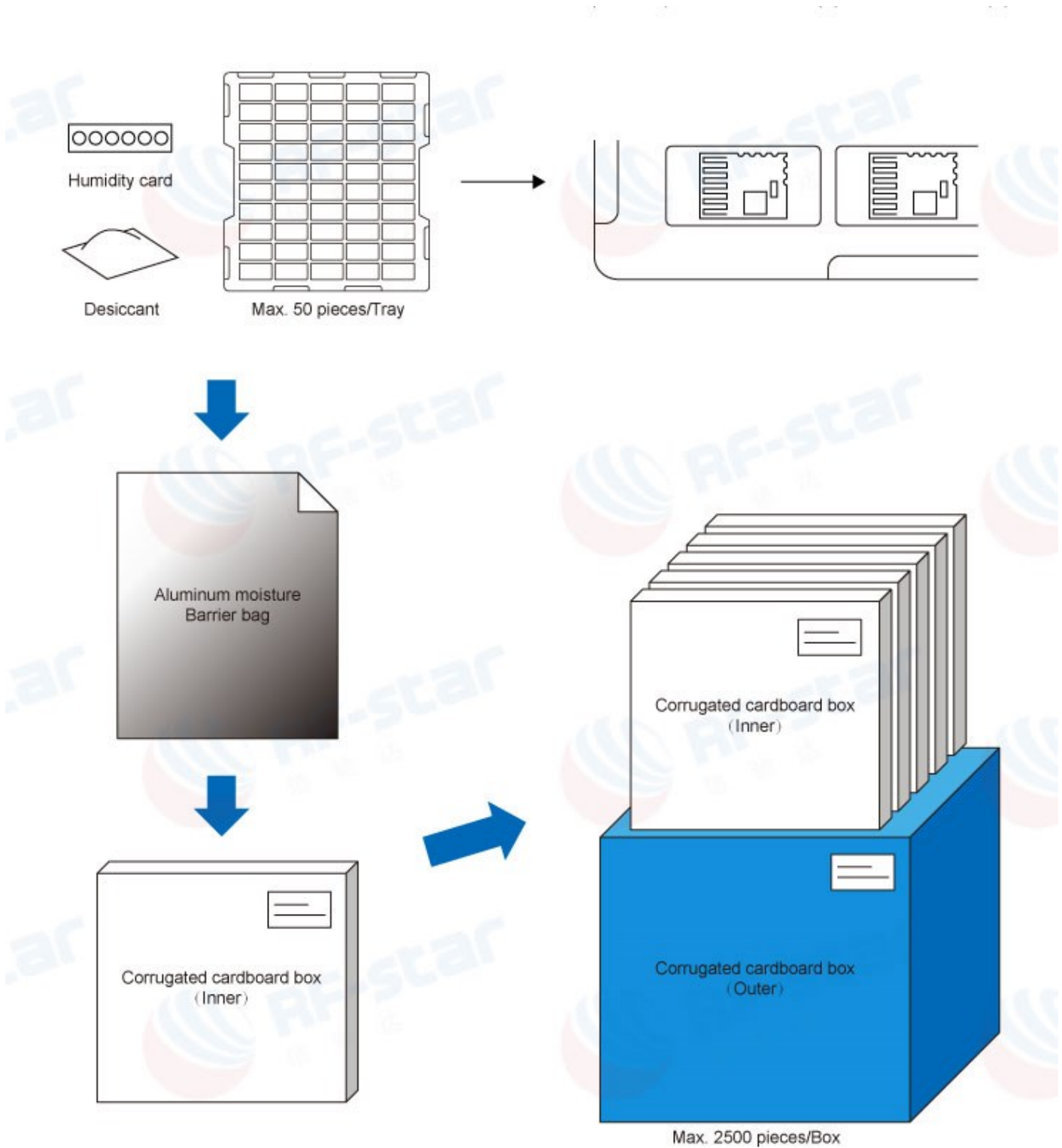

Figure 11. Default Package by Tray

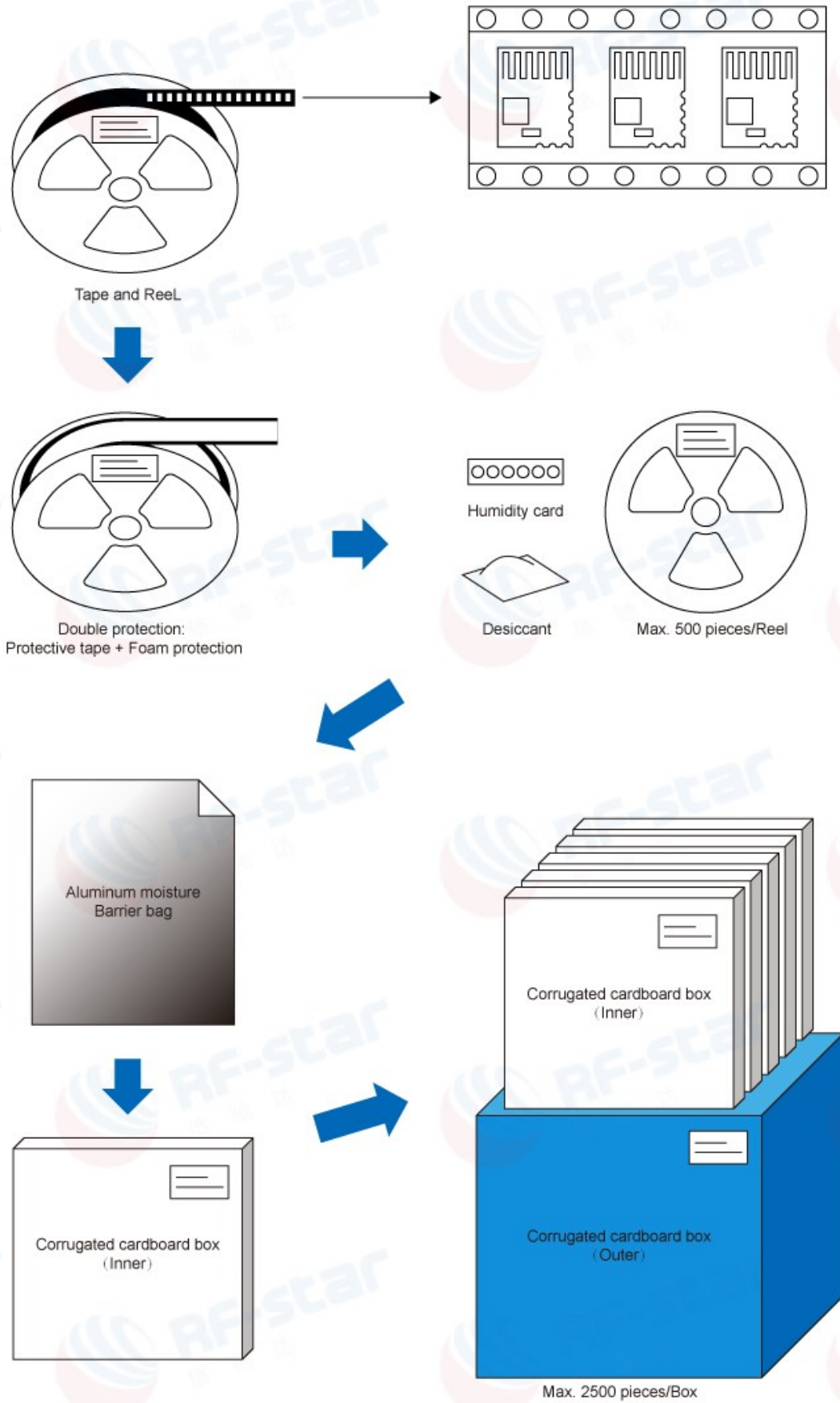

Figure 12. Package by Tape & Reel

7 Certificate

7.1 FCC

This device complies with part 15 of the FCC Rules. Operation is subject to the following two conditions: (1) This device may not cause harmful interference, and (2) this device must accept any interference received, including interference that may cause undesired operation.

FCC ID: 2ABN2-2340B1

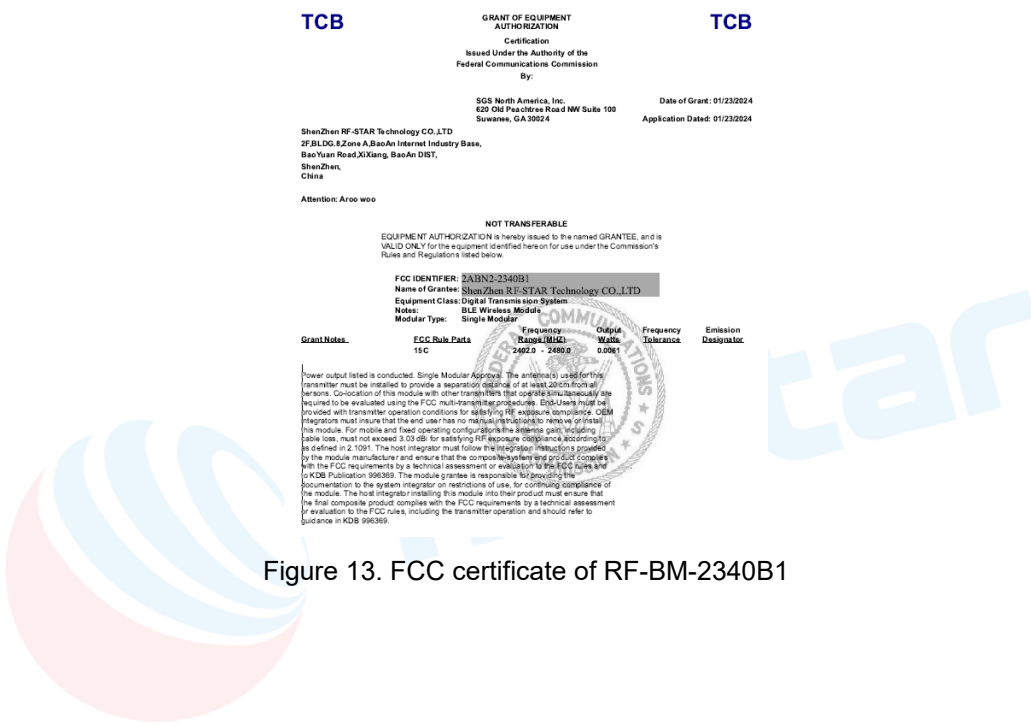

Figure 13. FCC certificate of RF-BM-2340B1

7.2 CE



Figure 14. CE certificate of RF-BM-2340B1

7.3 IC

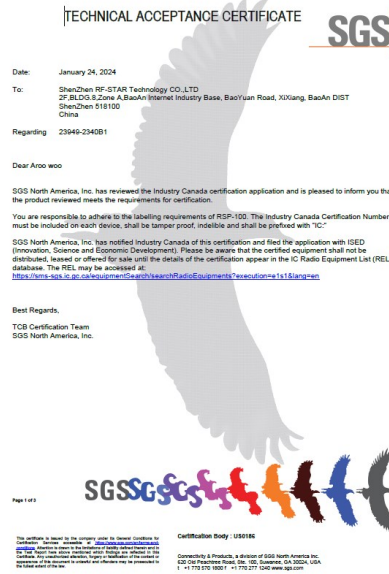

Figure 15. IC certificate of RF-BM-2340B1

7.4 Reach



Figure 16. Reach of RF-BM-2340B1

7.5 RoHS

Verification Report No.: SZXEC23003008901 Date: Jan 05, 2024 Page 1 of 7

Client Name: SHENZHEN RF-STAR TECHNOLOGY CO., LTD.
 Client Address: ROOM 502-503, BLOCK12-A5, SHENZHEN BAY SCIENCE AND TECHNOLOGY ECOLOGICAL PARK, NANSHAN DISTRICT, SHENZHEN, CHINA

Sample Name: BLE Wireless Module
 Tested Basic Model No.: RF-BM-2340B1
 The above sample(s) and information were provided by the client.

SGS Job No.: SZP23-030352
 Sample Receiving Date: Dec 01, 2023
 Verification Period: Dec 01, 2023 ~ Jan 05, 2024
 Verification Requested: With reference to RoHS Directive (EU) 2015/863 amending 2011/65/EU.
 Verification Method(s): Please refer to next page(s).
 Verification Result(s): Please refer to next page(s).

Test Result Summary:

Test Items	Conclusion
EU RoHS Directive (EU) 2015/863 amending Annex II to Directive 2011/65/EU - Lead, Mercury, Cadmium, Hexavalent chromium, Polybrominated biphenyls (PBBs), Polybrominated diphenyl ethers (PBDEs), Bis(2-ethylhexyl) phthalate (DEHP), Butyl benzyl phthalate (BBP), Dibutyl phthalate (DBP) and Diisobutyl phthalate (DIBP)	Pass

Signed for and on behalf of
 SGS-CSTC Standards Technical Services Co., Ltd. Shenzhen Branch

Andy Ni
 Approved Signatory

Member of the SGS Group (SGS SA)

Figure 17. RoHS of RF-BM-2340B1

7.6 SRRC

编号: 2024-1838
 Certificate No.

无线电发射设备型号核准证
 Radio Transmission Equipment Type Approval Certificate

深圳市信驰达科技有限公司:

根据《中华人民共和国无线电管理条例》，经审查，下列设备准予颁发无线电发射设备型号核准证。

In accordance with the Radio Regulations of the People's Republic of China, after examination, the Radio Transmission Equipment Type Approval Certificate is granted to the following equipment.

设备名称:	蓝牙模块
Equipment Name	
设备型号:	RF-BM-2340B1
Equipment Type	
核准代码:	23J44396R580
CMIIT ID	
主要功能:	数据传输
Main Functions	
有效期:	五年
Validity	

其他事项载于附页。
 Additional items as Seen in Attachments.

Sealed by Issuing Authority
 2024年09月04日
 Year Month Date

中华人民共和国工业和信息化部制作
 Issued by the Ministry of Industry and Information Technology of the People's Republic of China

Figure 18. SRRC certificate of RF-BM-2340B1

7.7 TSCA

Test Report No.: SZXEC2300262701 Date: Jan 04, 2024 Page 1 of 4

Client Name: SHENZHEN RF-STAR TECHNOLOGY CO., LTD.
 Client Address: ROOM 502-503, BLOCK12-A6, SHENZHEN BAY SCIENCE AND TECHNOLOGY ECOLOGICAL PARK, NANSHAN DISTRICT, SHENZHEN, CHINA

Sample Name: BLE Wireless Module
 Model No.: RF-BM-2340B1
 The above sample(s) and information were provided by the client.

SGS Job No.: SZP23-039707
 Sample Receiving Date: Dec 28, 2023
 Testing Period: Dec 28, 2023 - Jan 04, 2024
 Test Requested: Select test(s) as requested by the client.
 Test Method(s): Please refer to next page(s).
 Test Result(s): Please refer to next page(s).

Test Requirement	Conclusion
Persistent, Bioaccumulative, and Toxic (PBT) Chemicals under US EPA Toxic Substances Control Act (TSCA) Section 6(b)	Pass

Signed for and on behalf of
 SGS-CSTC Standards Technical Services Co., Ltd. Shenzhen Branch

Fay Yuan
 Fay Yuan
 Approved Signatory

Member of the SGS Group (SIF 54)

Figure 19. TSCA of RF-BM-2340B1

7.8 BQB

Project Details

Project Name: BLE Wireless Module
 Product Type: End Product
 TSCA Version: YCRL 2023-1

Referenced Qualified Design(s):
 201833

Previously Qualified Design Used in this Qualification(s):
 2024-01-11

Listing Date: 2024-01-11
 Declaration ID: D067533

Name	Website	Category	Unique ID	Model Number	Description
RF-star	www.rfstar.com	Unique	1/112004	RF-BM-2340B1	RF-BM-2340B1 are RF modules based on TI lower power CC2640RS SoC. BLE Product 120000 2340B1 They are multiprotocol 2.4 GHz wireless module supporting Thread, ZigBee, and Bluetooth 5.3 Low Energy. IEEE 802.15.4, and proprietary 2.4 GHz. The modules integrate a 48 MHz crystal, 512 KB of in-system Programmable Flash, 32 KB ROM for boot-loader, and 38 KB of on-chip memory SRAM. The ARM Cortex-M0+ core application processor can operate at an extremely low current at flexible power modes.

Member Company: Shenzhen RF STAR Technology CO., LTD.

Declaring Member Contact / Listing Contact Person:
 Name: Aiden Xie
 Address: Room 502-503, Block 12-A6, Shenzhen Bay Science and Technology Ecological Park, Nanshan District, Shenzhen, China
 City: Shenzhen
 State: Guangdong
 Country: China
 Postal Code: 518063

Complete the Project and Submit Product(s) for Qualification

By typing my name or other symbol of my signature into the "Signature" field below, I agree on behalf of Shenzhen RF STAR Technology CO., LTD. ("Company") to Bluetooth Launch Studio Terms of Use, and I make the following representations and warranties personally and on behalf of Company. The following representations and warranties, together with all project information and the Bluetooth Launch Studio Terms of Use, are the Supplier Declaration of Conformity and Declaration of Compliance described in the Program Reference Document (PRD) and Declaration Process Document (DPD).

I am authorized by Company to submit all of the information included in this project and all information is complete and accurate.

Company does not, by its governing documents or other applicable law, require more than one signatory, a stamp or seal, or a witnessed signature to be legally bound.

I agree on behalf of Company to contract in English and electronically, and adopt the characters and symbols input in the signature field below as my signature, with the same effect as an ink signature.

Figure 20. BQB of RF-BM-2340B1

8 Revision History

Date	Version No.	Description
2023.09.01	V1.0	The initial version is released.
2023.12.20	V1.0	Update the recommended PCB footprint.
2024.05.20	V1.0	Add the certificates. Update the Recommended PCB Footprint of RF-BM-2340B1(I). Update the Photo of RF-BM-2340B1.
2024.06.06	V1.1	Add the no floating specification of the debugging IOs. Update the reference design.

Note:

1. The document will be optimized and updated from time to time. Before using this document, please make sure it is the latest version.
2. To obtain the latest document, please download it from the official website: www.rfstariot.com and www.szrfstar.com.

9 Contact Us

SHENZHEN RF-STAR TECHNOLOGY CO., LTD.

Shenzhen HQ:

Add.: Room A503, Podium Building No. 12, Shenzhen Bay Science and Technology Ecological Park, Nanshan District, Shenzhen, Guangdong, China, 518063

Tel.: 86-755-8632 9829

Chengdu Branch:

Add.: N2-1604, Global Center, North No. 1700, Tianfu Avenue, Hi-Tech District, Chengdu, Sichuan, China, 610095

Tel.: 86-28-8692 5399

Email: sunny@szrfstar.com, sales@szrfstar.com

Web.: www.rfstariot.com, www.szrfstar.com

